

EVAPORADOR CÚBICO INDUSTRIAL / INDUSTRIAL CUBIC EVAPORATOR

IRP / ICP / IFP.: 7,9 KW - 168,5 KW

ALTO RENDIMIENTO PARA CÁMARAS INDUSTRIALES DE REFRIGERACIÓN Y CONGELACIÓN

- Esta gama consta de 124 modelos de evaporadores cúbicos.
- Diseñados para aplicaciones de frío industrial en refrigeración a alta y media temperatura (serie IRP) disponible con capacidades entre 12 y 168 KW (10.325 y 144.920 Kcal/h)
- Diseñados para aplicaciones de frío industrial en congelación a baja temperatura (serie ICP) disponible con capacidades entre 9,5 y 139 KW (8.248 y 119.594 Kcal/h) o (serie IFP) disponible con capacidades entre 7,9 y 121,5 KW (6.860 y 104.498 Kcal/h).

HIGH-PERFORMANCE, FOR INDUSTRIAL COOLING AND FREEZING CHAMBERS

- This range of Industrial cubic evaporators consists of 124 models.
- Has been designed for both industrial chilling applications at high and medium temperature and industrial freezing applications at low temperatures.
- The IRP series (4 mm fin spacing) is designed for high and medium temperature with cooling capacities from 12 to 168 KW (10.325 to 144.920 Kcal/h).
- The ICP (7mm fin spacing) and IFP (10mm fin spacing) series are designed for industrial freezing applications with the following cooling capacities: ICP series from 9,5 to 139 KW (8.248 to 119.594 Kcal/h); IFP series from 7,9 to 121,5 kw (6.860 to 104.498 Kcal/h).

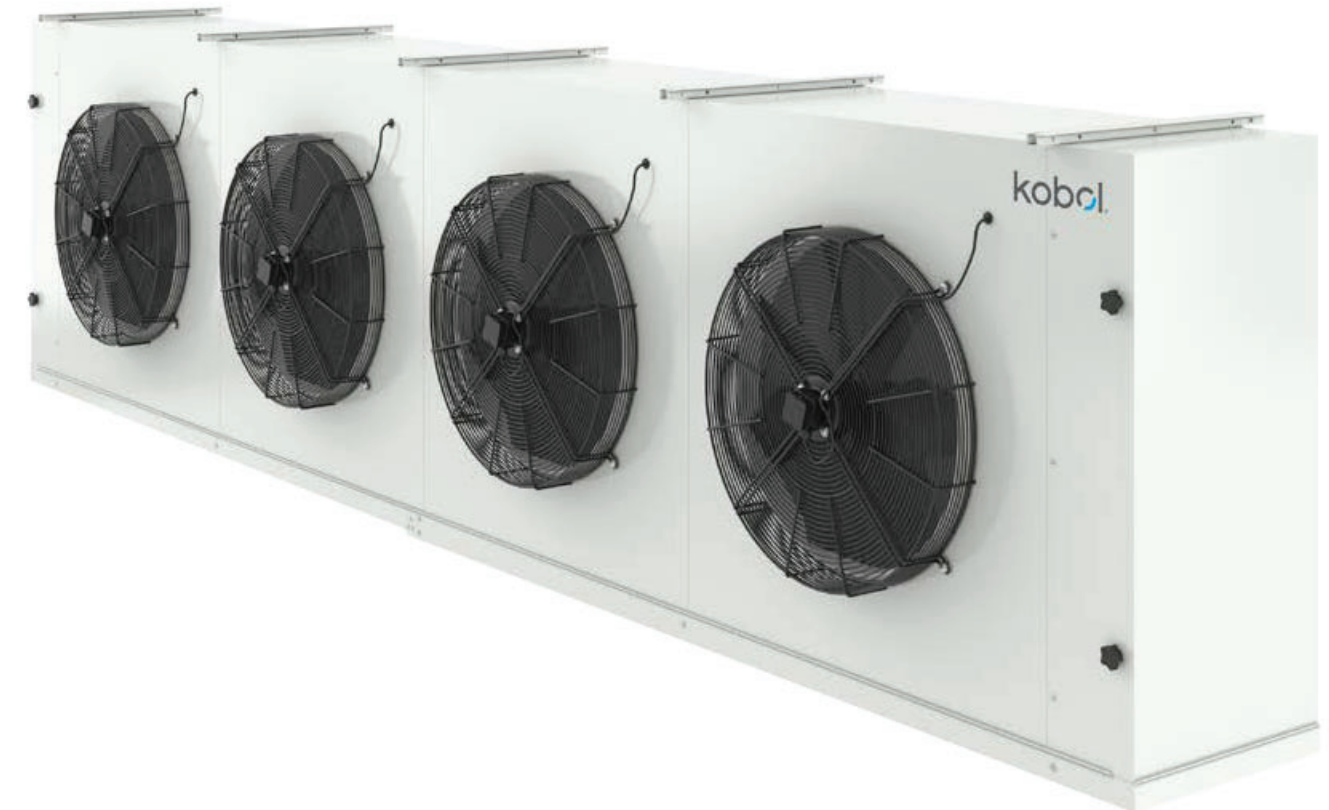

Evaporador cúbico industrial frontal
Frontal Industrial cubic unit cooler



Evaporador cúbico industrial lateral
Lateral Industrial cubic unit cooler

Evaporador cúbico industrial
Industrial cubic unit cooler

CARACTERÍSTICAS TÉCNICAS TECHNICAL FEATURES

BATERÍAS ALETEADAS

- Construidas con tubo de cobre de Ø 1/2" fabricado según la especificación CUPROCLIMA, y con aletas de aluminio corrugadas.
- La disposición de los tubos de cobre al tresbolillo a través de aletas autoseparadas, la perfección del ajuste entre ambos elementos, y la utilización de aletas corrugadas permiten la obtención de elevadas eficiencias.
- El paso de aleta es de 4 mm en la serie IRP, de 7 mm en la ICP y de 10 mm en la serie IFP.
- Todas las baterías son sometidas a una prueba de fugas con una presión de ensayo de 3.923kPa (40 kg/cm²) y posteriormente son presurizadas con nitrógeno a 147 kPa (1,5kg/cm²) para prevenir la corrosión de la superficie interior de los tubos de cobre.

CARROCERÍA

- Está realizada con chapa de acero galvanizado y pintada con pintura epoxy-poliéster polimerizada al horno a 180°C, que le confiere una alta resistencia a la corrosión incluso en condiciones ambientales extremas. Además, este acabado permite cumplir con las más estrictas normas de higiene alimentaria.
- Carcasa de Ø 450 mm sin pintar (Mg - Al).
- Incorpora doble bandeja de desescarche para facilitar el drenaje del agua resultante del mismo.
- Está dotado de separadores internos para evitar el efecto "by- pass" durante el funcionamiento secuencial de los ventiladores.
- Tanto las bandejas de desescarche como los paneles laterales de la carrocería son fácilmente desmontables, con lo que el acceso al interior de los aparatos es cómodo y rápido.

VENTILADORES Y MOTORES

- Los ventiladores utilizados son de Ø 450mm, 630mm o 800mm (dependiendo del modelo), dotados de motores trifásicos de (230V / 400V @ 50-60 Hz) de rotor externo, aislamiento clase B, grado de protección IP-54, funcionan a temperaturas comprendidas entre -40°C y +40°C e incorporan protección térmica.
- Las rejillas de protección son de varilla de acero cincado pintado y llevan incorporada una caja de bornes estanca a la que se conectan los motores de los ventiladores.
- Todos los evaporadores se envían con conexionados de serie.

FINNED COILS

- Manufactured by using copper tubes of Ø 1/2" diameter according to CUPROCLIMA * specifications and aluminum corrugated fins.
- The staggered arrangement of the copper tubes throughout the self spaced fins, the accurate link between both tubes and fins as well as the use of corrugated fins result in high performance coils.
- Fin spacing is 4 mm in IRP series, 7 mm in ICP series and 10 mm in IFP series.
- Every coil has been subjected to leakage test under a rate of pressure of 3,923 kPa (40 kg/cm²) and then pressurized by using nitrogen at 147 kPa (1,5 kg/cm²) in order to avoid the corrosion of the inner surface of the copper tubes.

CASEWORK

- The metal casing work of the unit is manufactured in galvanized steel. Its external surface is painted epoxy-polyester and then baked and cured at 180°C (365°F). This process allows the equipment to meet the highest food hygiene standard.
- Casework for 450mm fan diameter coolers is unpainted (Mg-Al).
- The casework includes double drip tray to drain the water resulting from the defrost process internal structure with partitions to avoid the by-pass effect caused by the fans sequential operation.
- For better maintenance, the drip tray and end plates are readily dismantled from the casework giving an easy and fast access to the inside.

FANS AND MOTORS

- Fans diameter are Ø 450mm, 630mm or 800mm depending on the model. They are equipped with external rotor three-phase motors (230 V / 400V @ 50-60 Hz) with class B insulation, grade protection IP.54, thermal protection device and working on a temperature range from -40°C to +40°C (-40°F to 104°F).
- Painted fan guards are made of zinc plated steel wire and includes a water tight terminal box where the fans are wired. Motor fan connections come as standard.

RESISTENCIAS DE DESESCARCHE

- Van incorporadas de serie en los ICP, IFP y son opcionales en la serie IRP.
- Están blindadas con tubo de acero inoxidable, sus terminales están vulcanizadas sobre el tubo para evitar derivaciones e incorporan toma de tierra individual.
- Se ubican estratégicamente en el evaporador con el objeto de facilitar un desescarche adecuado y uniforme. Las rejillas de protección son de varilla de acero cincado.

CAPACIDADES FRIGORÍFICAS

- Las capacidades frigoríficas de los evaporadores se determinan según la norma ENV 328 condición 2 (temperatura de evaporación del refrigerante -8°C y temperatura de entrada del aire 0°C) en los IRP y las capacidades frigoríficas de los evaporadores de la serie ICP, IFP según la condición 3 (temperatura de evaporación -25°C y temperatura de entrada del aire -18°C); en ambos casos con superficie de aleta seca.
- Los restantes valores que aparecen en las tablas están relacionadas con diversas temperaturas de evaporación y de cámara de refrigeración, en todos los casos en condiciones de aleta húmeda [incremento de un 25% (IRP) y de un 12% (en la serie ICP, IFP) sobre los resultados obtenidos con aleta seca].
- Las capacidades frigoríficas de nuestras tablas se han determinado utilizando R-404A. Si quisieramos calcular con otro tipo de refrigerante, partiendo de la capacidad necesaria, debemos de multiplicar la misma por el factor de corrección correspondiente e ir a seleccionar a nuestras tablas con el dato obtenido.

EMBALAJE

- El precio incluye un embalaje de protección preparado para una fácil elevación e instalación (Ø 630mm and Ø 800mm).

ELECTRIC DEFROST

- Electric heaters are included in the ICP, IFP series and are optional in the IRP series.
- They are shielded by a stain-less steel tube and their terminals are vulcanized over it to avoid electric shunts; every heater includes a single ground wire.
- They are strategically located across the finned coil in order to provide suitable and uniform defrosting.

COOLING CAPACITIES

- The stated cooling capacity is established according to ENV328 standard test condition 2: refrigerant evaporation temperature -8°C (17.6°F) and entering air temperature 0°C (32°F) for the IRP series unit cooler. For the ICP/IFP series, the stated cooling capacity is established according to condition 3: refrigerant evaporation temperature -25°C (13°F) and air inlet temperature -18°C (-0.4°F) for the ICP/IFP series. In both cases, dry fin surface condition is considered.
- The other stated values for cooling capacities on the tables are related to different evaporation and cold room temperatures and are valid for wet fin surface condition (increasing the dry values by 25% in IRP series and 12% in ICP/IFP ones).
- The cooling capacity has been fixed using refrigerant R-404A. If we would like calculate with other refrigerant, based on the required capacity, we must multiply it by the corresponding correction factor and then go to select on our tables with the data obtained.

PACKAGING

- Price includes protective packaging ready to be lifted with a forklift at installation site (Ø 630mm and 800mm).

REFRIGERANTE REFRIGERANT	R-134a	R-22	R-404A	R-407A	R-407C	R-507	R-410A	R-407F	R-448A	R-449A
F1	1,07	1,038	1	1,17	1,135	1	1	0,83	0,91	0,91

OPCIONES Y ACCESORIOS OPTIONS & ACCESSORIES

MATERIAL DE ALETA

- Aleta de Cobre
- Aleta Lacada

CARCASA

- Aluminio (solo para Ø450)
- Pintada
- Acero Inoxidable

DESESCARCHE

- Desescarche por gas caliente
- Desescarche por gas caliente en batería y eléctrico en bandeja
- Desescarche eléctrico (solo para IRP)
- Desescarche por agua
- Aros de resistencia en el ventilador

OTRAS

- Tratamiento Blygold
- Ventiladores de Alta Eficiencia

REFRIGERANTES

- R134a, R404A, R407F, R448A, R449A...
- Agua Glicolada
- CO2

FIN MATERIAL

- Copper Fins
- Coated Fins

CASING

- Aluminium (only for Ø450)
- Painted
- Stainless Steel

DEFROST

- Hot gas defrost
- Hot gas defrost in coil and electric in tray
- Electric defrost (only for IRP)
- Water defrost
- Fan ring heaters

OTHER

- Blygold
- High Efficiency Fans

COOLANTS

- R134a, R404A, R407F, R448A, R449A...
- Water Glycol
- CO2

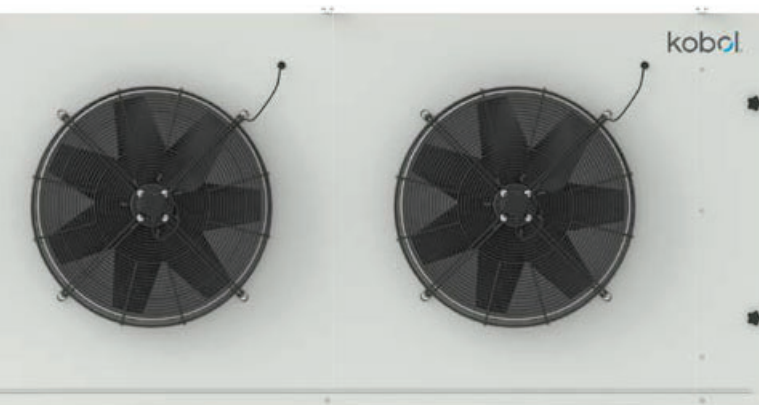

OPCIONES Y ACCESORIOS OPTIONS & ACCESSORIES

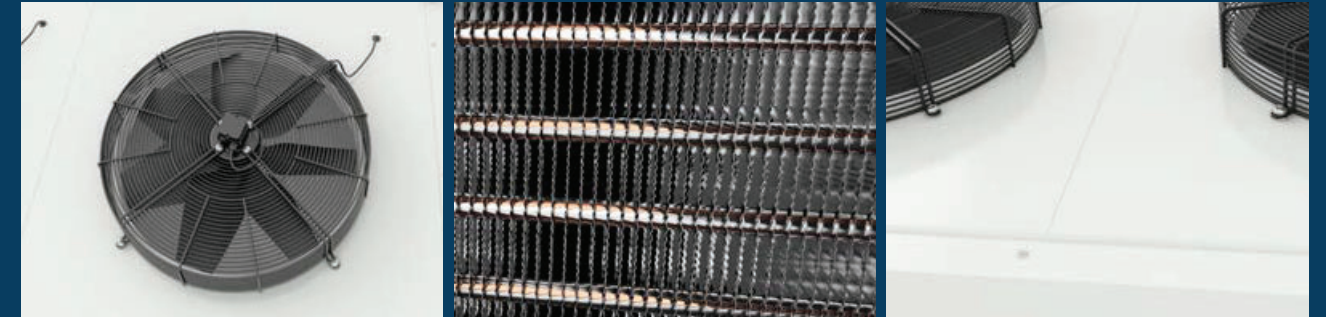

Ventilador trifásico de rotor externo
External rotor three-phase motor

Preparado para CO2, Agua gliconada,
R407F... Ready to use with CO2, Glycol,
R407F, R448A, R449A...

Separadores internos para evitar el by-pass
Internal structure to avoid the by-pass effect



Desescarche eléctrico
Electric defrost

Opción de motor EC
EC fan option

Conexiones eléctricas incluidas
Electric connections included



DATOS TÉCNICOS TECHNICAL INFORMATION

SERIE IRP / IRP SERIES

PASO DE ALETAS / FIN SPACING: 4 mm

R-404A

MODELO MODEL	CAPACIDAD CAPACITY	ENV 328 COND.2	Tev = -5°C				SUPERFICIE SURFACE m2	CAUDAL DE AIRE AIR FLOW m3/h	DARDO AIR THROW m*	VOLUMEN INTERNO INTERNAL VOLUME dm3	PESO WEIGHT kg
			DT1 = 5	DT1 = 7	DT1 = 8	DT1 = 10					
IRP-87	W	8.700	6.525	9.831	12.006	16.008	42	5.200	20	11	47
IRP-142	W	14.270	10.703	16.125	19.693	26.257	56	11.500	22	15	69
IRP-174	W	17.460	13.095	19.730	24.095	32.126	84	10.400	22	22	83
IRP-213	W	21.340	16.005	24.114	29.449	39.266	84	17.250	24	22	98
IRP-227	W	22.790	17.093	25.753	31.450	41.934	111	15.000	38	30	179
IRP-256	W	25.620	19.215	28.951	35.356	47.141	148	14.000	36	39	198
IRP-263	W	26.300	19.725	29.719	36.294	48.392	126	15.600	24	34	120
IRP-285	W	28.530	21.398	32.239	39.371	52.495	112	23.000	26	30	129
IRP-308	W	30.810	23.108	34.815	42.518	56.690	168	19.000	37	48	273
IRP-350	W	35.080	26.310	39.640	48.410	64.547	169	20.800	26	45	157
IRP-363	W	36.330	27.248	41.053	50.135	66.847	148	32.400	41	39	275
IRP-461	W	46.130	34.598	52.127	63.659	84.879	221	30.000	39	63	311
IRP-496	W	49.640	37.230	56.093	68.503	91.338	224	42.000	41	62	414
IRP-548	W	54.840	41.130	61.969	75.679	100.906	221	48.600	45	60	389
IRP-619	W	61.970	46.478	70.026	85.519	114.025	335	38.000	38	89	469
IRP-693	W	69.310	51.983	78.320	95.648	127.530	332	45.000	43	88	443
IRP-750	W	75.010	56.258	84.761	103.514	138.018	443	42.000	40	116	495
IRP-901	W	90.150	67.613	101.870	124.407	165.876	442	60.000	48	117	572
IRP-931	W	93.140	69.855	105.248	128.533	171.378	503	57.000	44	134	663
IRP-976	W	97.690	73.268	110.390	134.812	179.750	450	84.000	53	121	745
IRP-1221	W	122.110	91.583	137.984	168.512	224.682	675	76.000	49	178	854

* Velocidad de aire residual / Residual air speed: 0,25 m/s

SERIE ICP / ICP SERIES

PASO DE ALETAS / FIN SPACING: 7 mm

R-404A

MODELO MODEL	CAPACIDAD CAPACITY	ENV 328 COND.3	Tev = -5°C				Tev = -25°C			SUPERFICIE SURFACE m2	CAUDAL DE AIRE AIR FLOW m3/h	DARDO AIR THROW m*	VOLUMEN INTERNO INTERNAL VOLUME dm3	PESO WEIGHT kg
			DT1 = 5	DT1 = 7	DT1 = 8	DT1 = 10	DT1 = 5	DT1 = 7	DT1 = 8					
ICP-60	W	6.030	5.213	7.854	9.591	12.788	4.764	6.754	7.960	24	5.650	20	11	45
ICP-93	W	9.380	7.988	12.035	14.697	19.596	7.410	10.506	12.382	32	12.300	22	15	65
ICP-121	W	12.190	10.478	15.786	19.279	25.705	9.630	13.653	16.091	48	11.300	22	22	77
ICP-139	W	13.960	12.090	18.216	22.246	29.661	11.028	15.635	18.427	48	18.450	24	22	93
ICP-156	W	15.610	13.530	20.385	24.895	33.194	12.332	17.483	20.605	63,3	15.900	40	30	172
ICP-180	W	18.040	16.013	24.126	29.463	39.284	14.252	20.205	23.813	84,4	15.000	38	39	189
ICP-184	W	18.490	16.178	24.374	29.767	39.689	14.607	20.709	24.407	64,2	24.600	26	30	121
ICP-219	W	21.940	18.833	28.374	34.652	46.202	17.333	24.573	28.961	95,8	20.800	39	48	262
ICP-230	W	23.010	20.303	30.589	37.357	49.809	18.178	25.771	30.373	84,4	33.600	44	39	266
ICP-243	W	24.360	21.045	31.708	38.723	51.630	19.244	27.283	32.155	96,3	22.600	26	45	146
ICP-314	W	31.460	27.158	40.917	49.970	66.626	24.853	35.235	41.527	126,6	31.800	41	63	297
ICP-348	W	34.810	30.615	46.127	56.332	75.109	27.500	38.987	45.949	126,6	50.400	48	60	375
ICP-354	W	35.460	32.085	48.341	59.036	78.715	28.013	39.715	46.807	168,8	30.000	38	79	329
ICP-428	W	42.870	37.890	57.088	69.718	92.957	33.867	48.014	56.588	191,6	41.600	40	89	448
ICP-431	W	43.120	40.560	61.110	74.630	99.507	34.065	48.294	56.918	168,8	67.200	53	78	484
ICP-473	W	47.320	40.778	61.438	75.031	100.041	37.383	52.998	62.462	189,9	47.700	45	88	422
ICP-510	W	51.020	47.558	71.653	87.506	116.674	40.306	57.142	67.346	253,2	45.000	42	116	467
ICP-590	W	59.030	54.300	81.812	99.912	133.216	46.634	66.114	77.920	253,2	63.600	50	117	544
ICP-611	W	61.110	56.865	85.677	104.632	139.509	48.277	68.443	80.665	257	88.000	56	121	716
ICP-645	W	64.500	56.910	85.744	104.714	139.619	50.955	72.240	85.140	287,4	62.400	47	134	631
ICP-830	W	83.060	75.578	113.870	139.063	185.417	65.617	93.027	109.639	385,6	83.200	52	178	811

* Velocidad de aire residual / Residual air speed: 0,25 m/s

DATOS TÉCNICOS TECHNICAL INFORMATION

SERIE IFP / IFP SERIES

PASO DE ALETAS / FIN SPACING: 10 mm

R-404A

MODELO MODEL	CAPACIDAD CAPACITY	ENV 328 COND.3	Tev = -5°C				Tev = -31°C				SUPERFICIE SURFACE	CAUDAL DE AIRE AIR FLOW	DARDO AIR THROW	VOLUMEN INTERNO INTERNAL VOLUME	PESO WEIGHT
			DT1 = 5	DT1 = 7	DT1 = 8	DT1 = 10	DT1 = 5	DT1 = 6	DT1 = 7	DT1 = 8					
IFP-51	W	5.120	4.335	6.531	7.976	10.635	3.729	4.483	5.196	6.076	16,8	5.850	20	11	44
IFP-75	W	7.530	6.435	9.695	11.840	15.787	5.580	6.709	7.775	9.092	22,4	12.500	22	15	64
IFP-103	W	10.330	8.835	13.311	16.256	21.675	7.556	9.084	10.528	12.311	33,6	11.700	22	22	75
IFP-115	W	11.500	9.840	14.826	18.106	24.141	8.455	10.165	11.780	13.775	33,6	18.750	24	22	90
IFP-136	W	13.630	11.693	17.617	21.514	28.686	10.039	12.070	13.987	16.356	44,25	16.400	42	30	169
IFP-153	W	15.330	13.200	19.888	24.288	32.384	11.294	13.578	15.736	18.401	44,9	25.000	26	30	118
IFP-163	W	16.340	14.205	21.402	26.137	34.850	12.033	14.466	16.765	19.604	59	15.700	40	39	184
IFP-188	W	18.840	16.410	24.724	30.194	40.259	13.786	16.574	19.208	22.461	67,1	21.500	41	48	258
IFP-198	W	19.890	17.175	25.877	31.602	42.136	14.703	17.676	20.485	23.954	59	34.400	45	39	261
IFP-206	W	20.620	17.738	26.725	32.637	43.516	15.228	18.308	21.216	24.810	67,4	23.400	26	45	141
IFP-274	W	27.410	23.445	35.324	43.139	57.518	20.265	24.364	28.235	33.017	88,5	32.800	43	63	297
IFP-300	W	30.050	25.898	39.019	47.651	63.535	22.250	26.750	31.000	36.250	88,5	51.600	49	60	368
IFP-323	W	32.360	28.628	43.132	52.675	70.233	23.692	28.483	33.009	38.599	118	31.400	40	79	319
IFP-379	W	37.930	32.925	49.607	60.582	80.776	27.848	33.480	38.800	45.371	134	43.000	42	89	438
IFP-412	W	41.200	35.198	53.031	64.763	86.351	30.491	36.658	42.482	49.677	133	49.200	47	88	412
IFP-470	W	47.040	42.608	64.195	78.398	104.530	34.078	40.970	47.480	55.521	177	47.100	44	116	453
IFP-529	W	52.920	47.318	71.292	87.064	116.086	38.608	46.417	53.791	62.901	177	65.600	52	117	530
IFP-537	W	53.760	48.878	73.642	89.935	119.913	38.946	46.823	54.262	63.452	180	90.800	58	121	703
IFP-570	W	57.020	49.440	74.490	90.970	121.293	41.910	50.386	58.392	68.281	201	64.500	50	134	616
IFP-738	W	73.850	66.038	99.497	121.509	162.012	53.854	64.746	75.032	87.740	270	86.000	55	178	791

* Velocidad de aire residual / Residual air speed: 0,25 m/s

CARACTERÍSTICAS COMUNES COMMON FEATURES

MODELO MODEL	VENTILADORES FANS		SPEED (1360 rpm) CONSUMO ENERGÉTICO Y DE INTENSIDAD POWER & INTENSITY CONSUMPTION		ENTRADA INLET	SALIDA OUTLET	RESISTENCIAS HEATERS			
	N	Ø (mm)	W	A	Ø	Ø	W	A		
IRP-87	ICP-60	IFP-51	1	ø450	480	0,98	5/8"	1 1/8"	3.432	5,9
IRP-142	ICP-93	IFP-75	2	ø450	960	1,96	7/8"	1 3/8"	5.170	8,5
IRP-174	ICP-121	IFP-103	2	ø450	960	1,96	1 1/8"	1 5/8"	6.440	11
IRP-213	ICP-139	IFP-115	3	ø450	1.440	2,94	1 1/8"	1 5/8"	7.475	12,3
IRP-263			3	ø450	1.440	2,94	1 3/8"	2 1/8"	9.300	15,9
IRP-285	ICP-184	IFP-153	4	ø450	1.920	3,92	1 3/8"	2 1/8"	10.556	18,1
IRP-350	ICP-243	IFP-206	4	ø450	1.920	3,92	1 3/8"	2 1/8"	12.640	18,7
IRP-227	ICP-156	IFP-136	1	ø630	1.900	3,2	1 1/8"	1 5/8"	9.696	14,2
IRP-256	ICP-180	IFP-163	1	ø630	1.900	3,2	1 3/8"	2 1/8"	13.760	20,8
IRP-363	ICP-230	IFP-198	2	ø630	3.800	6,4	1 3/8"	2 1/8"	14.282	22,3
IRP-461	ICP-314	IFP-274	2	ø630	3.800	6,4	1 5/8"	2 1/8"	18.312	27,1
	ICP-354	IFP-323	2	ø630	3.800	6,4	1 5/8"	2 5/8"	26.528	40
IRP-548	ICP-348	IFP-300	3	ø630	5.700	9,6	1 5/8"	2 5/8"	21.272	33,2
IRP-693	ICP-473	IFP-412	3	ø630	5.700	9,6	2x 1 3/8"	2x 2 1/8"	27.280	39,7
IRP-750	ICP-510	IFP-470	3	ø630	5.700	9,6	2x 1 3/8"	2x 2 1/8"	39.296	59,3
	ICP-431		4	ø630	7.600	12,8	2x 1 3/8"	2x 2 1/8"	28.184	44
IRP-901	ICP-590	IFP-529	4	ø630	7.600	12,8	2x 1 5/8"	2x 2 5/8"	36.144	52,6
IRP-308	ICP-219	IFP-188	1	ø800	1.800	3,8	1 3/8"	2 1/8"	14.060	22,1
IRP-496			2	ø800	3.600	7,6	1 3/8"	2 5/8"	20.035	32,4
IRP-619	ICP-428	IFP-379	2	ø800	3.600	7,6	2 X 1 3/8"	2X 2 1/8"	27.490	43,2
IRP-931	ICP-645	IFP-570	3	ø800	5.400	11,4	2 X 1 5/8"	2X 2 5/8"	40.180	59,4
IRP-976	ICP-611	IFP-537	4	ø800	7.200	15,2	2 X 1 5/8"	2X 2 5/8"	38.304	55,8
IRP-1221	ICP-830	IFP-738	4	ø800	7.200	15,2	2X 1 5/8"	2X 2 5/8"	50.958	74,1

PLANOS DRAWING

ø 450 mm.

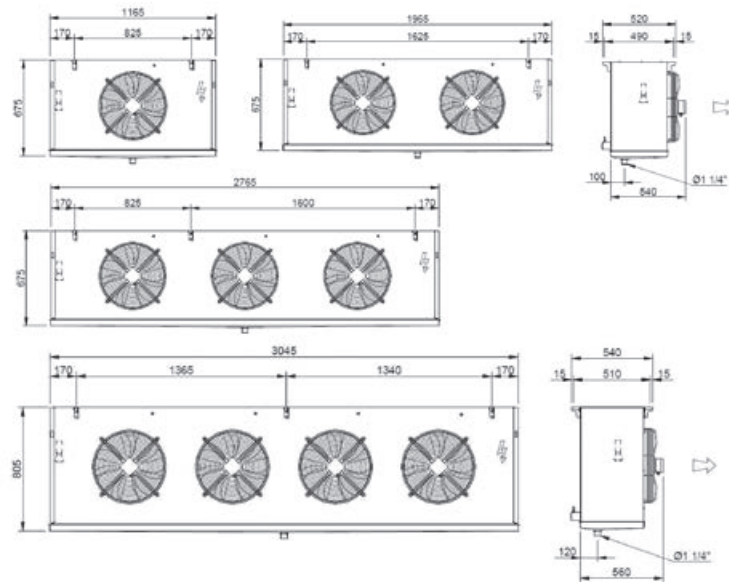

ø 630 mm.

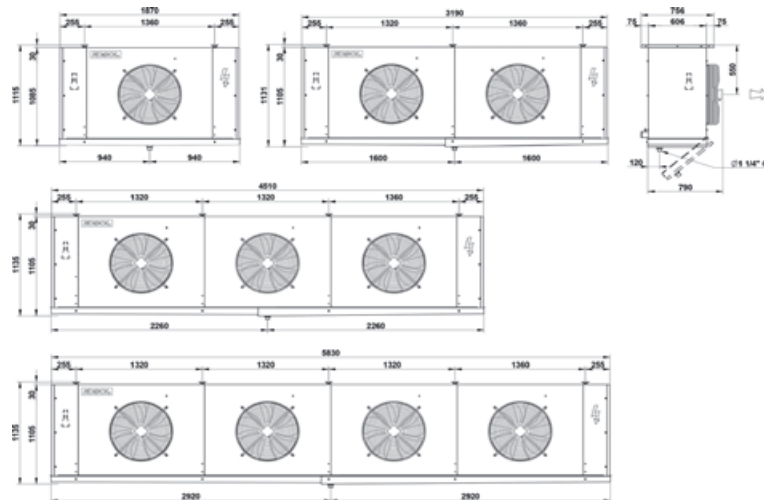

ø 800 mm.

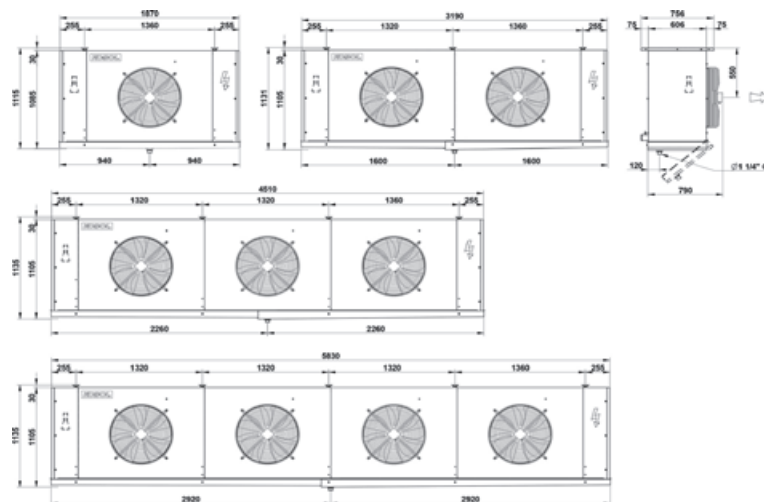

ELECCIÓN DE LA «DT» EN LOS EVAPORADORES «DT» CHOICE FOR EVAPORATORS

ELECCIÓN

- La elección de la «DT» adecuada para una cámara frigorífica en función de la humedad relativa que necesita el producto a conservar.
- Para la elección de la «DT» utilizando este diagrama debemos trazar una línea horizontal desde la humedad relativa deseada hasta cortar la curva, y desde el punto de intersección trazar una línea vertical hasta cortar al eje horizontal, con lo que obtendremos la «DT».
- A efectos de selección del evaporador, podemos considerar que la temperatura de la cámara frigorífica es igual a la temperatura de entrada del aire a la batería del evaporador, es decir, que: $T_{ea} = T_{cf}$.

THE CHOICE

- The choice of the suitable «DT» for an unit cooler working inside a cold storage room depends on the relative humidity the goods to be stored need.
- To select the «DT» using this chart we must draw one horizontal straight line from the relative humidity percentage wanted up to cut the plotted curve, then, we draw one downwards line from the crossover point up to cut the horizontal axis. At this point we read the «DT» value we are looking for.
- Usually designers and technicians work considering that the cold room temperature is equal to the entering air temperature at the coil's unit cooler. Such approximation do not cause a loss of accuracy in the unit cooler's selection. Thus, we consider: $T_{ea} = T_{cr}$ and so: $DT = T_{cr} - T_{ev}$.

