

HDA

INDUSTRIAL DEHUMIDIFIERS

Dehumidifying capacity from 73 l/24h to 200 l/24h
Air flow from 800 m³/h to 1800 m³/h

R410A



HDA dehumidifiers series are high-performances units especially designed for industrial or commercial purposes where humidity level should be controlled or water vapor condensation should be prevented. These units are particularly indicated for archives, ironing rooms, bookstores, cheese factories, underground rooms, cellars and industrial sites where high humidity level is present. This series comprises 4 models which cover a capacity range from 73 to 200 l/24h. HDA units are designed for easy maintenance and service, each part being readily accessible and, when required, easily replaceable thus reducing service and maintenance costs. The units are supplied with a solenoid valves set for the hot gas injection used to defrost the evaporator in case of severe working conditions.

Temperature and humidity probes are accessories supplied on request.

VERSIONS

The series includes 4 models with air flows from 800 to 1800 m³/h.

TECHNICAL DATA

| HDA | | 75 | 100 | 150 | 200 |
|------------------------------------|-------------------|----------|----------|----------|----------|
| Moisture removed at 30°C - 80% | l/24h | 78,5 | 109,2 | 133,9 | 175,9 |
| Moisture removed at 30°C - 60% | l/24h | 56,3 | 77,9 | 105,9 | 140,5 |
| Moisture removed at 27°C - 60% | l/24h | 49,5 | 68,8 | 100,0 | 128,2 |
| Moisture removed at 20°C - 60% | l/24h | 35,4 | 49,1 | 73,0 | 91,2 |
| Moisture removed at 10°C - 70% | l/24h | 25,3 | 35,2 | 55,2 | 68,3 |
| Nominal input power ⁽¹⁾ | kW | 1,4 | 1,8 | 2,2 | 2,8 |
| Maximum input power | kW | 1,9 | 2,1 | 2,9 | 3,6 |
| Maximum input current | A | 7,9 | 9,6 | 13,0 | 16,7 |
| Peak current | A | 25,0 | 38,0 | 41,6 | 64,6 |
| Air Flow | m ³ /h | 800 | 1000 | 1500 | 1800 |
| Available static pressure | Pa | 50÷150 | 50÷150 | 50÷150 | 50÷150 |
| Refrigerant | | R410A | R410A | R410A | R410A |
| Global warming potential (GWP) | | 2088 | 2088 | 2088 | 2088 |
| Refrigerant charge | kg | 0,55 | 0,55 | 1,10 | 1,10 |
| Equivalent CO2 charge | t | 1,15 | 1,15 | 2,30 | 2,30 |
| Sound power ⁽²⁾ | dB(A) | 59 | 61 | 67 | 69 |
| Sound pressure ⁽³⁾ | dB(A) | 45 | 47 | 52 | 54 |
| Power supply | V/Ph/Hz | 230/1/50 | 230/1/50 | 230/1/50 | 230/1/50 |

Performances are calculated with low fan speed and are referred to the following conditions:

(1) Temperature 30°C; Humidity 80%

(2) Sound Power level according to ISO EN 3744 fan with available static pressure 50 Pa.

(3) Sound Pressure level measured at 1 mt from the unit in free field conditions according with ISO EN 3744, fan with available static pressure 50 Pa.

PLANT SCHEME

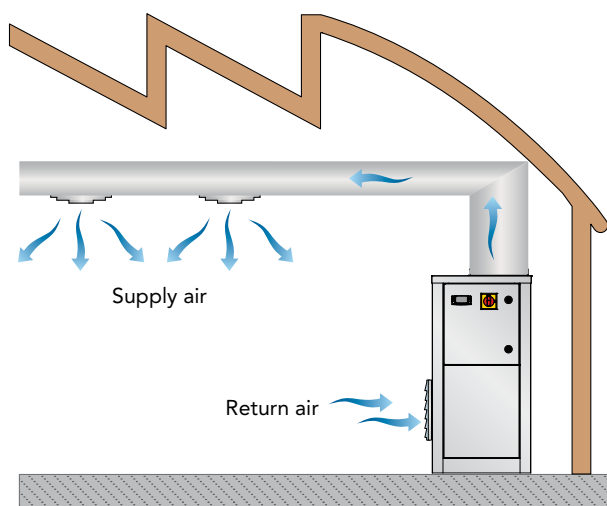

OPERATION LIMITS

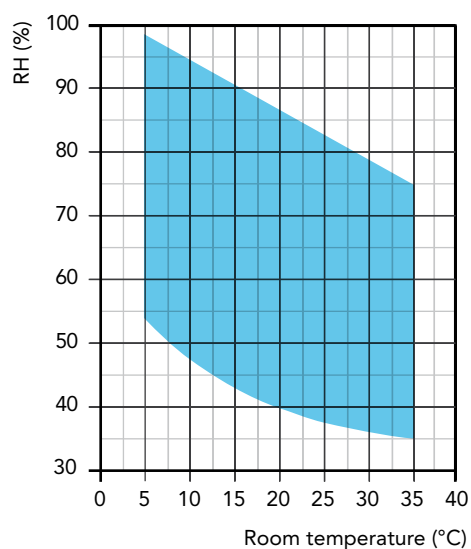

COMPONENTS

FRAME

All units are made from hot-galvanised thick sheet metal, painted with polyurethane powder enamel at 180°C to ensure the best resistance against the atmospheric agents. The frame is self-supporting with removable panels. All screws and rivets are in stainless steel. The colour of the units is RAL 9018.

REFRIGERANT CIRCUIT

The refrigerant gas used in these units is R410A. The refrigerant circuit is made by using international primary brands components and according to ISO 97/23 concerning welding procedures. The refrigerant circuit includes: sight glass, filter drier, thermal expansion valve with external equalizer, Schrader valves form maintenance and control, pressure safety device (according to PED regulation). All the units are supplied with injection valves kit for hot gas defrost cycle.

COMPRESSOR

The compressors are rotative type, with thermal overload protection by a klixon embedded in the motor winding. The compressor is mounted on rubber vibration dampers and it is supplied, standard, with sound-proof cover to reduce noise emission. The inspection is possible through the frontal panel of the unit that allows the maintenance of the compressor.

CONDENSER AND EVAPORATOR

Condensers and evaporators are made of copper pipes and aluminium fins.

The diameter of the copper pipes is 3/8" and the thickness of the aluminium fins is 0,1 mm. The tubes are mechanically expanded into the aluminium fins to improve the heat exchange factor. The geometry of these heat exchangers guarantees a low air side pressure drop and then the use of low rotation (and low noise emission) fans.

All units are supplied, standard, with a powder coated steel drip tray and all evaporators are supplied with a temperature sensor used as automatic defrost probe.

FAN

The fans are made of galvanized steel, centrifugal type. It is statically and dynamically balanced and supplied.

The electric motors are directly connected to the fan; they are all at 3 speeds, with integrated thermal protection. The protection class of the motors is IP 54.

AIR FILTER

It is made of synthetic filtering media, pleated type, without electro-static charge; they are all removable for differential disposal, ePM10 50% according to UNI EN ISO 16890:2017.

MICROPROCESSOR

All units are supplied standard with microprocessor controls. The microprocessor controls the following functions: compressor timing, automatic defrost cycles, alarms.

An appropriate LCD display shows the operation mode of the unit, set point and alarms.

ELECTRIC BOX

The electric switch board is made according to electromagnetic compatibility norms CEE 2014/35 and 2014/30. The accessibility to the board is possible after removing the front panel of the unit and the OFF positioning of the main switch. The following

components are also standard installed: main switch, magnetic-thermal switches (as a protection fans and compressors), control circuit automatic breakers, compressor contactors, fan contactors. The terminal board is supplied with voltage free contacts for remote ON-OFF and general alarm.

CONTROL AND PROTECTION DEVICES

All units are supplied with the following control and protection devices: antifreeze protection sensor, high pressure switch with manual reset, low pressure switch with automatic reset, high pressure safety valve, compressor thermal overload protection, fans thermal overload protection.

TEST

All the units are fully assembled and wired at the factory, carefully evacuated and dried after leak tests under pressure and then charged with refrigerant R410A.

They are all fully operational tested before shipment. They all conforms to European Directives and are individually marked with the CE label and provided with Conformity Declaration.

ACCESSORY DESCRIPTIONS

CANA - Delivery flange for channel connection

Press-folded rectangular flange for connection to the ducts and installed on the fan expulsion mouth.

FARC - Air filter with frame for ducted installation

Complete with efficiency class air filter which can be removed by the side and frame for ducted installation.

HYGR - Remote mechanical hygostat

To be installed on the wall, it is supplied with a regulation knob and working range from 30% to 100% with precision of 3%.

INOX - Stainless steel frame

It's used to ensure the best resistance against the atmospheric agents and the operation in aggressive environments. The frame is made of stainless steel AISI 304, self-supporting with removable panels to facilitate inspection and maintenance of internal components. All screws and rivets are in stainless steel.

INSE - Serial interface card RS485

This interface card enables the controller to communicate with other devices using Modbus protocol.

KAVG - Rubber vibration dampers

To be installed beneath the unit base and the ground to avoid the transmission of vibrations (and the noise) to the building.

LS00 - Low noise version

This version includes the complete acoustic insulation of the unit (compressor + heat exchangers vanes) with compressor jackets and insulating material made with high density media and the interposition of heavy bitumen layer.

PCRL - Remote control panel

This panel can be mounted up to 50m (maximum) from the unit and replicates all of the control functions. It is connected using a twin cable of 0.5 mm sq section.

RGDD - Humidity and Temperature electronic probe sensor

Built-in Electronic temperature and humidity probe.

TROL - Floor trolley version

To facilitate dehumidifier handling where is placed.

V1CE - E.C. Supply fan

The supply fan is a high performance centrifugal type, double inlet forward curved blades, directly coupled to the electric motor. The fan wheel and the scroll are made from hot galvanised thick sheet metal, painted with polyurethane powders, to ensure the best resistance against aggressive environments.

The electric motor is a high efficiency DC brushless type with

external rotor, to guarantee an ideal cooling of the windings and the absence of power lost due to pulleys and belt transmission. The fan is statically and dynamically balanced class 6,3 according to ISO1940.

The electric motor has a separate electronic commutator (driver) and a speed modulation 0-10V, integrated PFC, burn out thermal protection (in case of considerable reduction of the power supply), protection degree IP54, serial interface card with mod-bus protocol RTU.

ACCESSORIES

| HDA | | 75 | 100 | 150 | 200 |
|--|------|----|-----|-----|-----|
| A.C. fans ≤ 150 Pa | | ● | ● | ● | ● |
| Supply flange | CANA | ● | ● | ● | ● |
| Hot gas defrost | | ● | ● | ● | ● |
| Thermostatic valve | | ● | ● | ● | ● |
| Low noise version | LS00 | ● | ● | ● | ● |
| Main switch | | ● | ● | ● | ● |
| Rubber vibration dampers | KAVG | ○ | ○ | ○ | ○ |
| Remote mechanical hygostat | HYGR | ○ | ○ | ○ | ○ |
| Floor trolley version | TROL | ○ | ○ | ○ | ○ |
| Stainless steel frame | INOX | ○ | ○ | ○ | ○ |
| Air filter with frame for ducted installation | FARC | ○ | ○ | ○ | ○ |
| Humidity and Temperature electronic probe sensor | RGDD | ○ | ○ | ○ | ○ |
| Remote control Panel | PCRL | ○ | ○ | ○ | ○ |
| High efficiency E.C. fans ≤ 300 Pa | V1CE | ○ | ○ | ○ | ○ |
| Serial interface card RS485 | INSE | ○ | ○ | ○ | ○ |

● Standard, ○ Optional, – Not available.

CONFIGURATIONS

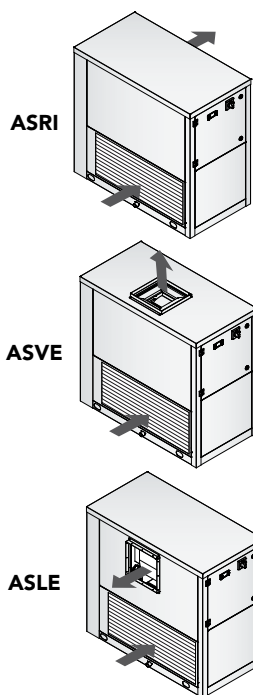

F1

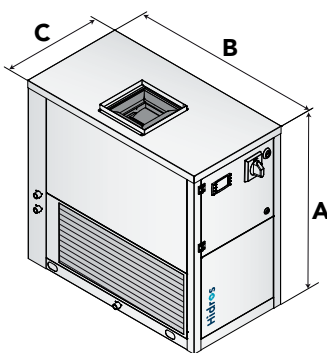

F2

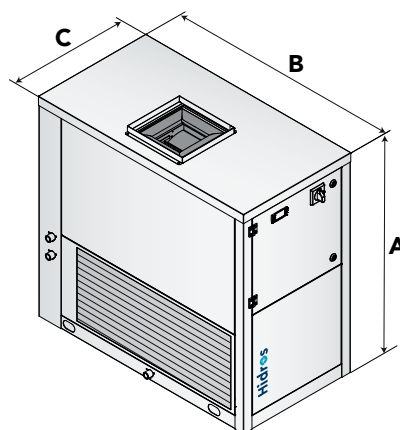

| Mod. | Frame | A (mm) | B (mm) | C (mm) | kg |
|------|-------|--------|--------|--------|-----|
| 75 | F1 | 800 | 800 | 400 | 85 |
| 100 | F1 | 800 | 800 | 400 | 90 |
| 150 | F2 | 1000 | 1060 | 550 | 130 |
| 200 | F2 | 1000 | 1060 | 550 | 135 |