

LHE

HIGH EFFICIENCY AIR TO WATER HEAT PUMPS WITH LOW GWP REFRIGERANT

Heating power from 45 kW to 457 kW

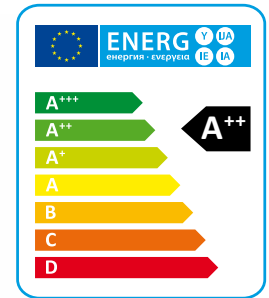

LHE high-efficiency air/water heat pumps are particularly suitable for applications where maximum efficiency in heating mode and a low noise level are required. The units are specifically designed to provide the best efficiency in heating mode; they can operate at outside temperatures down to -20°C and produce water up to a temperature of 60°C.

All sizes are supplied with reverse cycle valve used for winter defrost; the RV versions are also able to produce cold water in summer period (not available for HH versions).

VERSIONI

- HH** Heating only.
- RV** Reversible heating/cooling.
- HA** High efficiency, AC fans.
- HE** High efficiency, EC fans.
- LS** Low noise.
- XL** Super low noise.
- P2U** 2 pipe systems without domestic hot water production.
- P2S** 2 pipe systems with domestic hot water production by external 3 way valve.

TECHNICAL DATA

Reversible heating/cooling version (RV)

HA/LS/HH-RV P2U		452	512	682	752	912	1102	1152	1352	1502	1612
Heating capacity (EN14511) ⁽¹⁾	kW	45,4	51,4	68,7	74,6	87,9	101,0	112,0	129,0	150,0	161,0
Total input power (EN14511) ⁽¹⁾	kW	11,7	13,0	16,3	18,4	22,7	25,3	28,4	33,5	38,4	40,6
COP (EN14511) ⁽¹⁾	W/W	3,88	3,95	4,21	4,05	3,87	3,99	3,94	3,85	3,91	3,97
Energy Class ⁽²⁾		A+	A+	A++	A++	A+	A++	A++	A+	A+	A+
SCOP ⁽²⁾	kWh/kWh	3,68	3,74	4,08	4,00	3,52	3,85	3,86	3,69	3,69	3,75
η _{s,h} ⁽²⁾	%	144	147	160	157	138	151	151	145	145	147
Cooling capacity (EN14511) ⁽³⁾	kW	37,7	43,2	57,1	61,0	76,7	86,9	96,0	112,0	125,0	136,0
Total input power (EN14511) ⁽³⁾	kW	14,0	16,4	21,3	24,6	26,5	30,3	35,0	38,3	44,3	48,5
EER (EN14511) ⁽³⁾	W/W	2,69	2,63	2,68	2,48	2,89	2,87	2,74	2,92	2,82	2,80
TER (EN14511) ⁽⁴⁾	W/W	5,58	5,78	6,04	5,82	5,98	5,94	6,04	5,91	5,80	5,92
Sound power ⁽⁵⁾	dB (A)	77	76	77	78	82	83	85	86	87	87
Sound pressure ⁽⁶⁾	dB (A)	46	44	45	46	50	51	53	54	55	55
HE/LS/HH-RV P2U		452	512	682	752	912	1102	1152	1352	1502	1612
Heating capacity (EN14511) ⁽¹⁾	kW	45,0	51,5	68,7	75,0	91,0	102,0	114,0	134,0	150,0	161,0
Total input power (EN14511) ⁽¹⁾	kW	11,2	13,0	16,3	18,4	21,4	24,5	27,0	31,6	36,6	38,9
COP (EN14511) ⁽¹⁾	W/W	4,02	3,96	4,21	4,08	4,25	4,16	4,22	4,24	4,10	4,14
Energy Class ⁽²⁾		A++	A++	A++	A++	A++	A++	A++	A++	A++	A++
SCOP ⁽²⁾	kWh/kWh	3,98	3,90	4,19	4,13	3,92	4,10	4,14	4,02	4,08	4,03
η _{s,h} ⁽²⁾	%	156	153	165	162	154	161	163	158	160	158
Cooling capacity (EN14511) ⁽³⁾	kW	36,9	43,2	57,6	61,5	76,5	85,5	95,0	112,0	124,0	134,0
Total input power (EN14511) ⁽³⁾	kW	14,1	16,5	21,2	24,5	25,8	30,3	34,6	37,3	43,6	48,1
EER (EN14511) ⁽³⁾	W/W	2,62	2,62	2,72	2,51	2,97	2,82	2,75	3,00	2,84	2,79
TER (EN14511) ⁽⁴⁾	W/W	6,19	5,78	6,04	5,82	5,98	5,94	6,04	5,91	5,80	5,92
Sound power ⁽⁵⁾	dB (A)	78	79	81	82	86	87	88	89	89	90
Sound pressure ⁽⁶⁾	dB (A)	46	47	49	50	54	55	56	57	56	57
Power supply	V/Ph/Hz	400/3/50	400/3/50	400/3/50	400/3/50	400/3/50	400/3/50	400/3/50	400/3/50	400/3/50	400/3/50
Compressors / Circuits	n° / n°	2 / 1	2 / 1	2 / 1	2 / 1	2 / 1	2 / 1	2 / 1	2 / 1	2 / 1	2 / 1
Fans	n°	2	2	2	2	2	2	2	3	3	3
Refrigerant		R454B	R454B	R454B	R454B	R454B	R454B	R454B	R454B	R454B	R454B
Refrigerant charge	kg	10,0	14,5	19,0	19,0	27,0	27,0	27,0	36,0	36,0	36,0
Global warming potential (GWP)		466	466	466	466	466	466	466	466	466	466
Equivalent CO ₂ charge	t	4,7	6,8	8,9	8,9	12,6	12,6	12,6	16,8	16,8	16,8
Water tank volume	l	140	140	300	300	300	300	300	500	500	500
HA/LS/HH-RV P2U		1792	2012	2304	2312	2654	2954	3214	3514	3954	4454
Heating capacity (EN14511) ⁽¹⁾	kW	181,0	200,0	226,0	226,0	261,0	297,0	319,0	365,0	404,0	454,0
Total input power (EN14511) ⁽¹⁾	kW	45,7	50,0	56,7	56,0	68,5	78,0	82,8	94,1	105,0	116,0
COP (EN14511) ⁽¹⁾	W/W	3,96	4,00	3,99	4,04	3,81	3,81	3,85	3,88	3,85	3,91
Energy Class ⁽²⁾		A++	A++	A+	A++	A+	A+	A+	A+	A+	A+
SCOP ⁽²⁾	kWh/kWh	3,99	3,98	3,68	4,04	3,51	3,55	3,69	3,69	3,60	3,63
η _{s,h} ⁽²⁾	%	157	156	144	159	137	139	145	145	141	142
Cooling capacity (EN14511) ⁽³⁾	kW	160,0	175,0	197,0	195,0	229,0	254,0	271,0	306,0	352,0	387,0
Total input power (EN14511) ⁽³⁾	kW	57,0	62,8	70,3	69,4	78,3	91,9	100,0	116,0	125,0	141,0
EER (EN14511) ⁽³⁾	W/W	2,81	2,79	2,80	2,81	2,92	2,76	2,71	2,64	2,82	2,74
TER (EN14511) ⁽⁴⁾	W/W	6,20	6,11	6,01	6,11	5,89	5,77	5,83	5,81	6,76	6,89
Sound power ⁽⁵⁾	dB (A)	89	89	88	91	89	90	90	92	92	94
Sound pressure ⁽⁶⁾	dB (A)	57	57	56	58	56	58	58	60	59	62
HE/LS/HH-RV P2U		1792	2012	2304	2312	2654	2954	3214	3514	3954	4454
Heating capacity (EN14511) ⁽¹⁾	kW	182,0	202,0	227,0	230,0	261,0	298,0	320,0	366,0	405,0	455,0
Total input power (EN14511) ⁽¹⁾	kW	44,1	48,5	54,6	54,3	64,6	74,2	79,0	90,6	100,0	112,0
COP (EN14511) ⁽¹⁾	W/W	4,13	4,16	4,16	4,24	4,04	4,02	4,05	4,04	4,05	4,06
Energy Class ⁽²⁾		A++	A++	A++	A++	A++	A++	A++	A++	A++	A++
SCOP ⁽²⁾	kWh/kWh	4,25	4,20	4,12	4,20	3,92	4,01	4,05	4,06	4,04	4,01
η _{s,h} ⁽²⁾	%	167	165	162	165	154	157	159	159	159	157
Cooling capacity (EN14511) ⁽³⁾	kW	158,0	173,0	194,0	193,0	227,0	252,0	269,0	304,0	347,0	381,0
Total input power (EN14511) ⁽³⁾	kW	56,9	62,7	69,8	69,6	76,8	90,4	99,0	115,0	124,0	140,0
EER (EN14511) ⁽³⁾	W/W	2,78	2,76	2,78	2,77	2,96	2,79	2,72	2,64	2,80	2,72
TER (EN14511) ⁽⁴⁾	W/W	6,20	6,11	6,01	6,11	5,89	5,77	5,83	5,81	6,76	6,89
Sound power ⁽⁵⁾	dB (A)	90	92	91	92	91	92	92	93	91	89
Sound pressure ⁽⁶⁾	dB (A)	58	59	58	60	58	59	59	60	59	56
Power supply	V/Ph/Hz	400/3/50	400/3/50	400/3/50	400/3/50	400/3/50	400/3/50	400/3/50	400/3/50	400/3/50	400/3/50
Compressors / Circuits	n° / n°	2 / 1	2 / 1	4 / 2	2 / 1	4 / 2	4 / 2	4 / 2	4 / 2	4 / 2	4 / 2
Fans	n°	3	3	4	3	6	6	6	6	8	8
Refrigerant		R454B	R454B	R454B	R454B	R454B	R454B	R454B	R454B	R454B	R454B
Refrigerant charge	kg	45,0	45,0	60,0	60,0	72,0	72,0	72,0	72,0	90,0	100,0
Global warming potential (GWP)		466	466	466	466	466	466	466	466	466	466
Equivalent CO ₂ charge	t	20,9	20,9	27,9	27,9	33,6	33,6	33,6	33,6	41,9	46,6
Water tank volume	l	500	500	500	500	500	500	500	500	500	500

Performances are referred to the following conditions:

(1) Heating: Ambient temperature 7°C DB, 6°C WB, water temperature 30/35°C.

(2) Average conditions, low temperature, variable - Reg EU 811/2013

(3) Cooling: ambient air temperature 35°C, evaporator water temperature in/out 12/7 °C (only rv versions).

(4) TER: Total Energy Ratio - cold circuit 12/7°C, hot circuit 30/35°C.

(5) Sound power level in accordance with ISO 3744.

(6) Sound pressure level at 10 mt from the unit in free field conditions in accordance with ISO 3744.

Reversible heating/cooling version (RV)

HE

HA/XL/HH-RV P2U		452	512	682	752	912	1102	1152	1352	1502	1612
Heating capacity (EN14511) ⁽¹⁾	kW	45,2	51,0	67,6	73,6	89,9	102,0	112,0	133,0	148,0	160,0
Total input power (EN14511) ⁽¹⁾	kW	11,5	13,0	16,2	18,2	22,2	25,0	27,6	32,8	37,9	39,9
COP (EN14511) ⁽¹⁾	W/W	3,93	3,92	4,17	4,04	4,05	4,08	4,06	4,05	3,91	4,01
Energy Class ⁽²⁾		A++	A++	A++	A++	A+	A++	A++	A++	A++	A++
SCOP ⁽²⁾	kWh/kWh	3,88	3,97	4,07	4,02	3,79	4,12	4,14	3,98	3,95	4,02
η _{s,h} ⁽²⁾	%	152	156	160	158	149	162	163	156	155	158
Cooling capacity (EN14511) ⁽³⁾	kW	37,0	42,5	56,1	59,0	75,3	84,5	93,3	111,0	122,0	132,0
Total input power (EN14511) ⁽³⁾	kW	14,3	16,7	21,7	25,6	26,7	31,0	35,8	38,3	45,4	49,6
EER (EN14511) ⁽³⁾	W/W	2,59	2,54	2,59	2,30	2,82	2,73	2,61	2,90	2,69	2,66
TER (EN14511) ⁽⁴⁾	W/W	5,58	5,78	6,04	5,82	5,98	5,94	6,04	5,91	5,80	5,92
Sound power ⁽⁵⁾	dB (A)	72	71	71	72	74	76	78	80	81	81
Sound pressure ⁽⁶⁾	dB (A)	40	40	40	41	43	44	46	48	49	49
HE/XL/HH-RV P2U		452	512	682	752	912	1102	1152	1352	1502	1612
Heating capacity (EN14511) ⁽¹⁾	kW	44,6	51,2	68,2	74,1	89,4	101,0	111,0	132,0	148,0	158,0
Total input power (EN14511) ⁽¹⁾	kW	11,0	12,8	16,1	18,1	20,7	23,6	26,2	30,6	35,3	37,5
COP (EN14511) ⁽¹⁾	W/W	4,05	4,00	4,24	4,09	4,32	4,28	4,24	4,31	4,19	4,21
Energy Class ⁽²⁾		A++	A++	A++	A++	A++	A++	A++	A++	A++	A++
SCOP ⁽²⁾	kWh/kWh	4,00	4,02	4,19	4,13	4,24	4,35	4,39	4,29	4,27	4,24
η _{s,h} ⁽²⁾	%	157	158	165	162	167	171	173	169	168	167
Cooling capacity (EN14511) ⁽³⁾	kW	35,9	42,3	56,0	59,4	73,3	82,1	90,6	108,0	119,0	129,0
Total input power (EN14511) ⁽³⁾	kW	14,2	16,5	21,5	25,0	26,1	30,7	35,4	37,4	44,3	48,6
EER (EN14511) ⁽³⁾	W/W	2,53	2,56	2,60	2,38	2,81	2,67	2,56	2,89	2,69	2,65
TER (EN14511) ⁽⁴⁾	W/W	6,19	5,78	6,04	5,82	5,98	5,94	6,04	5,91	5,80	5,92
Sound power ⁽⁵⁾	dB (A)	72	71	71	72	74	76	78	80	81	81
Sound pressure ⁽⁶⁾	dB (A)	40	40	40	41	43	44	46	48	49	49
Power supply	V/Ph/Hz	400/3/50	400/3/50	400/3/50	400/3/50	400/3/50	400/3/50	400/3/50	400/3/50	400/3/50	400/3/50
Compressors / Circuits	n° / n°	2 / 1	2 / 1	2 / 1	2 / 1	2 / 1	2 / 1	2 / 1	2 / 1	2 / 1	2 / 1
Fans	n°	2	2	2	2	2	2	2	3	3	3
Refrigerant		R454B	R454B	R454B	R454B	R454B	R454B	R454B	R454B	R454B	R454B
Refrigerant charge	kg	10,0	14,5	19,0	19,0	27,0	27,0	27,0	36,0	36,0	36,0
Global warming potential (GWP)		466	466	466	466	466	466	466	466	466	466
Equivalent CO ₂ charge	t	4,7	6,8	8,9	8,9	12,6	12,6	12,6	16,8	16,8	16,8
Water tank volume	l	140	140	300	300	300	300	300	500	500	500

HA/XL/HH-RV P2U		1792	2012	2304	2312	2654	2954	3214	3514	3954	4454
Heating capacity (EN14511) ⁽¹⁾	kW	181,0	200,0	229,0	227,0	267,0	300,0	320,0	365,0	407,0	456,0
Total input power (EN14511) ⁽¹⁾	kW	44,2	49,3	55,9	55,0	66,8	76,6	80,9	92,0	101,0	113,0
COP (EN14511) ⁽¹⁾	W/W	4,10	4,06	4,10	4,13	4,00	3,92	3,96	3,97	4,03	4,04
Energy Class ⁽²⁾		A++	A++	A++	A++	A+	A+	A++	A++	A++	A++
SCOP ⁽²⁾	kWh/kWh	4,09	4,09	3,86	4,09	3,82	3,79	3,89	3,88	3,85	3,84
η _{s,h} ⁽²⁾	%	161	161	151	161	150	149	153	152	151	151
Cooling capacity (EN14511) ⁽³⁾	kW	154,0	171,0	191	188,0	222,0	247,0	263,0	294,0	342,0	374,0
Total input power (EN14511) ⁽³⁾	kW	58,9	64,0	72,4	72,2	80,1	94,0	103,0	121,0	128,0	145,0
EER (EN14511) ⁽³⁾	W/W	2,61	2,67	2,65	2,60	2,77	2,63	2,55	2,43	2,67	2,58
TER (EN14511) ⁽⁴⁾	W/W	6,20	6,11	6,01	6,11	5,89	5,77	5,83	5,81	6,76	6,76
Sound power ⁽⁵⁾	dB (A)	81	82	80	83	83	84	84	84	86	86
Sound pressure ⁽⁶⁾	dB (A)	49	51	49	52	51	52	52	52	53	54
HE/XL/HH-RV P2U		1792	2012	2304	2312	2654	2954	3214	3514	3954	4454
Heating capacity (EN14511) ⁽¹⁾	kW	179,0	199,0	222,0	225,0	260,0	291,0	312,0	352,0	395,0	434,0
Total input power (EN14511) ⁽¹⁾	kW	42,5	47,0	52,9	52,9	62,0	71,5	76,0	86,8	95,6	107,0
COP (EN14511) ⁽¹⁾	W/W	4,21	4,23	4,20	4,25	4,19	4,07	4,11	4,06	4,13	4,06
Energy Class ⁽²⁾		A++	A++	A++	A++	A++	A++	A++	A++	A++	A++
SCOP ⁽²⁾	kWh/kWh	4,33	4,33	4,37	4,31	4,14	4,18	4,18	4,19	4,20	4,07
η _{s,h} ⁽²⁾	%	170	170	172	169	163	164	164	165	165	160
Cooling capacity (EN14511) ⁽³⁾	kW	150,0	165,0	186,0	181,0	218,0	242,0	257,0	284,0	335,0	364,0
Total input power (EN14511) ⁽³⁾	kW	58,7	64,6	71,3	73,4	77,0	91,2	101,0	120,0	125,0	144,0
EER (EN14511) ⁽³⁾	W/W	2,56	2,55	2,61	2,47	2,83	2,65	2,54	2,37	2,68	2,53
TER (EN14511) ⁽⁴⁾	W/W	6,20	6,11	6,01	6,11	5,89	5,77	5,83	5,81	6,76	6,89
Sound power ⁽⁵⁾	dB (A)	81	82	80	83	83	84	84	84	86	86
Sound pressure ⁽⁶⁾	dB (A)	49	51	49	52	51	52	52	52	53	54
Power supply	V/Ph/Hz	400/3/50	400/3/50	400/3/50	400/3/50	400/3/50	400/3/50	400/3/50	400/3/50	400/3/50	400/3/50
Compressors / Circuits	n° / n°	2 / 1	2 / 1	4 / 2	2 / 1	4 / 2	4 / 2	4 / 2	4 / 2	4 / 2	4 / 2
Fans	n°	3	3	4	3	6	6	6	6	8	8
Refrigerant		R454B	R454B	R454B	R454B	R454B	R454B	R454B	R454B	R454B	R454B
Refrigerant charge	kg	45,0	45,0	60,0	60,0	72,0	72,0	72,0	72,0	90,0	100,0
Global warming potential (GWP)		466	466	466	466	466	466	466	466	466	466
Equivalent CO ₂ charge	t	20,9	20,9	27,9	27,9	33,6	33,6	33,6	33,6	41,9	46,6
Water tank volume	l	500	500	500	500	500	500	500	500	500	500

Performances are referred to the following conditions:

(1) Heating: Ambient temperature 7°C DB, 6°C WB, water temperature 30/35°C.

(2) Average conditions, low temperature, variable - Reg EU 811/2013

(3) Cooling: ambient air temperature 35°C, evaporator water temperature in/out 12/7 °C (only rv versions).

(4) TER: Total Energy Ratio - cold circuit 12/7°C, hot circuit 30/35°C.

(5) Sound power level in accordance with ISO 3744.

(6) Sound pressure level at 10 mt from the unit in free field conditions in accordance with ISO 3744.

Reversible heating/cooling version (RV)

HA/LS/HH-RV P2S		452	512	682	752	912	1102	1152	1352	1502	1612
Heating capacity (EN14511) ⁽¹⁾	kW	45,4	51,4	68,7	74,6	87,9	101,0	112,0	129,0	150,0	161,0
Total input power (EN14511) ⁽¹⁾	kW	11,7	13,0	16,3	18,4	22,7	25,3	28,4	33,5	38,4	40,6
COP (EN14511) ⁽¹⁾	W/W	3,88	3,95	4,21	4,05	3,87	3,99	3,94	3,85	3,91	3,97
Energy Class ⁽²⁾		A+	A+	A++	A++	A+	A++	A++	A+	A+	A+
SCOP ⁽²⁾	kWh/kWh	3,68	3,74	4,08	4,00	3,52	3,85	3,86	3,69	3,69	3,75
η _{s,h} ⁽²⁾	%	144	147	160	157	138	151	151	145	145	147
Cooling capacity (EN14511) ⁽³⁾	kW	37,7	43,2	57,1	61,0	76,7	86,9	96,0	112,0	125,0	136,0
Total input power (EN14511) ⁽³⁾	kW	14,0	16,4	21,3	24,6	26,5	30,3	35,0	38,3	44,3	48,5
EER (EN14511) ⁽³⁾	W/W	2,69	2,63	2,68	2,48	2,89	2,87	2,74	2,92	2,82	2,80
TER (EN14511) ⁽⁴⁾	W/W	5,58	5,78	6,04	5,82	5,98	5,94	6,04	5,91	5,80	5,92
Sound power ⁽⁵⁾	dB (A)	77	76	77	78	82	83	85	86	87	87
Sound pressure ⁽⁶⁾	dB (A)	46	44	45	46	50	51	53	54	55	55
HE/LS/HH-RV P2S		452	512	682	752	912	1102	1152	1352	1502	1612
Heating capacity (EN14511) ⁽¹⁾	kW	45,0	51,5	68,7	75,0	91,0	102,0	114,0	134,0	150,0	161,0
Total input power (EN14511) ⁽¹⁾	kW	11,2	13,0	16,3	18,4	21,4	24,5	27,0	31,6	36,6	38,9
COP (EN14511) ⁽¹⁾	W/W	4,02	3,96	4,21	4,08	4,25	4,16	4,22	4,24	4,10	4,14
Energy Class ⁽²⁾		A++	A++	A++	A++	A++	A++	A++	A++	A++	A++
SCOP ⁽²⁾	kWh/kWh	3,98	3,90	4,19	4,13	3,92	4,10	4,14	4,02	4,08	4,03
η _{s,h} ⁽²⁾	%	156	153	165	162	154	161	163	158	160	158
Cooling capacity (EN14511) ⁽³⁾	kW	36,9	43,2	57,6	61,5	76,5	85,5	95,0	112,0	124,0	134,0
Total input power (EN14511) ⁽³⁾	kW	14,1	16,5	21,2	24,5	25,8	30,3	34,6	37,3	43,6	48,1
EER (EN14511) ⁽³⁾	W/W	2,62	2,62	2,72	2,51	2,97	2,82	2,75	3,00	2,84	2,79
TER (EN14511) ⁽⁴⁾	W/W	6,19	5,78	6,04	5,82	5,98	5,94	6,04	5,91	5,80	5,92
Sound power ⁽⁵⁾	dB (A)	78	79	81	82	86	87	88	89	89	90
Sound pressure ⁽⁶⁾	dB (A)	46	47	49	50	54	55	56	57	56	57
Power supply	V/Ph/Hz	400/3/50	400/3/50	400/3/50	400/3/50	400/3/50	400/3/50	400/3/50	400/3/50	400/3/50	400/3/50
Compressors / Circuits	n° / n°	2 / 1	2 / 1	2 / 1	2 / 1	2 / 1	2 / 1	2 / 1	2 / 1	2 / 1	2 / 1
Fans	n°	2	2	2	2	2	2	2	3	3	3
Refrigerant		R454B	R454B	R454B	R454B	R454B	R454B	R454B	R454B	R454B	R454B
Refrigerant charge	kg	10,0	14,5	19,0	19,0	27,0	27,0	27,0	36,0	36,0	36,0
Global warming potential (GWP)		466	466	466	466	466	466	466	466	466	466
Equivalent CO ₂ charge	t	4,7	6,8	8,9	8,9	12,6	12,6	12,6	16,8	16,8	16,8
Water tank volume	l	140	140	300	300	300	300	300	500	500	500
HA/LS/HH-RV P2S		1792	2012	2304	2312	2654	2954	3214	3514	3954	4454
Heating capacity (EN14511) ⁽¹⁾	kW	181,0	200,0	226,0	226,0	261,0	297,0	319,0	365,0	404,0	454,0
Total input power (EN14511) ⁽¹⁾	kW	45,7	50,0	56,7	56,0	68,5	78,0	82,8	94,1	105,0	116,0
COP (EN14511) ⁽¹⁾	W/W	3,96	4,00	3,99	4,04	3,81	3,81	3,85	3,88	3,85	3,91
Energy Class ⁽²⁾		A++	A++	A+	A++	A+	A+	A+	A+	A+	A+
SCOP ⁽²⁾	kWh/kWh	3,99	3,98	3,68	4,04	3,51	3,55	3,69	3,69	3,60	3,63
η _{s,h} ⁽²⁾	%	157	156	144	159	137	139	145	145	141	142
Cooling capacity (EN14511) ⁽³⁾	kW	160,0	175,0	197,0	195,0	229,0	254,0	271,0	306,0	352,0	387,0
Total input power (EN14511) ⁽³⁾	kW	57,0	62,8	70,3	69,4	78,3	91,9	100,0	116,0	125,0	141,0
EER (EN14511) ⁽³⁾	W/W	2,81	2,79	2,80	2,81	2,92	2,76	2,71	2,64	2,82	2,74
TER (EN14511) ⁽⁴⁾	W/W	6,20	6,11	6,01	6,11	5,89	5,77	5,83	5,81	6,76	6,89
Sound power ⁽⁵⁾	dB (A)	89	89	88	91	89	90	90	92	92	94
Sound pressure ⁽⁶⁾	dB (A)	57	57	56	58	56	58	58	60	59	62
HE/LS/HH-RV P2S		1792	2012	2304	2312	2654	2954	3214	3514	3954	4454
Heating capacity (EN14511) ⁽¹⁾	kW	182,0	202,0	227,0	230,0	261,0	298,0	320,0	366,0	405,0	455,0
Total input power (EN14511) ⁽¹⁾	kW	44,1	48,5	54,6	54,3	64,6	74,2	79,0	90,6	100,0	112,0
COP (EN14511) ⁽¹⁾	W/W	4,13	4,16	4,16	4,24	4,04	4,02	4,05	4,04	4,05	4,06
Energy Class ⁽²⁾		A++	A++	A++	A++	A++	A++	A++	A++	A++	A++
SCOP ⁽²⁾	kWh/kWh	4,25	4,20	4,12	4,20	3,92	4,01	4,05	4,06	4,04	4,01
η _{s,h} ⁽²⁾	%	167	165	162	165	154	157	159	159	159	157
Cooling capacity (EN14511) ⁽³⁾	kW	158,0	173,0	194	193,0	227,0	252,0	269,0	304,0	349,0	384,0
Total input power (EN14511) ⁽³⁾	kW	56,9	62,7	69,8	69,6	76,8	90,4	99,0	115,0	124,0	140,0
EER (EN14511) ⁽³⁾	W/W	2,78	2,76	2,78	2,72	2,96	2,79	2,72	2,64	2,81	2,74
TER (EN14511) ⁽⁴⁾	W/W	6,20	6,11	6,01	6,11	5,89	5,77	5,83	5,81	6,76	6,89
Sound power ⁽⁵⁾	dB (A)	90	92	91	92	91	92	92	93	91	89
Sound pressure ⁽⁶⁾	dB (A)	58	59	58	60	58	59	59	60	59	56
Power supply	V/Ph/Hz	400/3/50	400/3/50	400/3/50	400/3/50	400/3/50	400/3/50	400/3/50	400/3/50	400/3/50	400/3/50
Compressors / Circuits	n° / n°	2 / 1	2 / 1	4 / 2	2 / 1	4 / 2	4 / 2	4 / 2	4 / 2	4 / 2	4 / 2
Fans	n°	3	3	4	3	6	6	6	6	8	8
Refrigerant		R454B	R454B	R454B	R454B	R454B	R454B	R454B	R454B	R454B	R454B
Refrigerant charge	kg	45,0	45,0	60,0	60,0	72,0	72,0	72,0	72,0	90,0	100,0
Global warming potential (GWP)		466	466	466	466	466	466	466	466	466	466
Equivalent CO ₂ charge	t	20,9	20,9	27,9	27,9	33,6	33,6	33,6	33,6	41,9	46,6
Water tank volume	l	500	500	500	500	500	500	500	500	500	500

Performances are referred to the following conditions:

(1) Heating: Ambient temperature 7°C DB, 6°C WB, water temperature 30/35°C.

(2) Average conditions, low temperature, variable - Reg EU 811/2013

(3) Cooling: ambient air temperature 35°C, evaporator water temperature in/out 12/7 °C (only rv versions).

(4) TER: Total Energy Ratio - cold circuit 12/7°C, hot circuit 30/35°C.

(5) Sound power level in accordance with ISO 3744.

(6) Sound pressure level at 10 mt from the unit in free field conditions in accordance with ISO 3744.

Reversible heating/cooling version (RV)

HE

HA/XL/HH-RV P2S		452	512	682	752	912	1102	1152	1352	1502	1612
Heating capacity (EN14511) ⁽¹⁾	kW	45,2	51,0	67,6	73,6	89,9	102,0	112,0	133,0	148,0	160,0
Total input power (EN14511) ⁽¹⁾	kW	11,5	13,0	16,2	18,2	22,2	25,0	27,6	32,8	37,9	39,9
COP (EN14511) ⁽¹⁾	W/W	3,93	3,92	4,17	4,04	4,05	4,08	4,06	4,05	3,91	4,01
Energy Class ⁽²⁾		A++	A++	A++	A++	A+	A++	A++	A++	A++	A++
SCOP ⁽²⁾	kWh/kWh	3,88	3,97	4,07	4,02	3,79	4,12	4,14	3,98	3,95	4,02
η _{s,h} ⁽²⁾	%	152	156	160	158	149	162	163	156	155	158
Cooling capacity (EN14511) ⁽³⁾	kW	37,0	42,5	56,1	59,0	75,3	84,5	93,3	111,0	122,0	132,0
Total input power (EN14511) ⁽³⁾	kW	14,3	16,7	21,7	25,6	26,7	31,0	35,8	38,3	45,4	49,6
EER (EN14511) ⁽³⁾	W/W	2,59	2,54	2,59	2,30	2,82	2,73	2,61	2,90	2,69	2,66
TER (EN14511) ⁽⁴⁾	W/W	5,58	5,78	6,04	5,82	5,98	5,94	6,04	5,91	5,80	5,92
Sound power ⁽⁵⁾	dB (A)	72	71	71	72	74	76	78	80	81	81
Sound pressure ⁽⁶⁾	dB (A)	40	40	40	41	43	44	46	48	49	49
HE/XL/HH-RV P2S		452	512	682	752	912	1102	1152	1352	1502	1612
Heating capacity (EN14511) ⁽¹⁾	kW	44,6	51,2	68,2	74,1	89,5	101,0	111,0	132,0	148,0	158,0
Total input power (EN14511) ⁽¹⁾	kW	11,0	12,7	16,0	18,0	20,6	23,6	26,0	30,5	35,3	37,4
COP (EN14511) ⁽¹⁾	W/W	4,05	4,03	4,26	4,12	4,34	4,28	4,27	4,33	4,19	4,22
Energy Class ⁽²⁾		A++	A++	A++	A++	A++	A++	A++	A++	A++	A++
SCOP ⁽²⁾	kWh/kWh	4,00	4,02	4,19	4,13	4,24	4,35	4,39	4,29	4,27	4,24
η _{s,h} ⁽²⁾	%	157	158	165	162	167	171	173	169	168	167
Cooling capacity (EN14511) ⁽³⁾	kW	36,3	42,6	56,3	59,8	73,8	82,7	91,2	108,0	120,0	130,0
Total input power (EN14511) ⁽³⁾	kW	14,2	16,5	21,5	25,1	26,1	30,7	35,5	37,5	44,5	48,7
EER (EN14511) ⁽³⁾	W/W	2,56	2,58	2,62	2,38	2,83	2,69	2,57	2,88	2,70	2,67
TER (EN14511) ⁽⁴⁾	W/W	6,19	5,78	6,04	5,82	5,98	5,94	6,04	5,91	5,80	5,92
Sound power ⁽⁵⁾	dB (A)	72	71	71	72	74	76	78	80	81	81
Sound pressure ⁽⁶⁾	dB (A)	40	40	40	41	43	44	46	48	49	49
Power supply	V/Ph/Hz	400/3/50	400/3/50	400/3/50	400/3/50	400/3/50	400/3/50	400/3/50	400/3/50	400/3/50	400/3/50
Compressors / Circuits	n° / n°	2 / 1	2 / 1	2 / 1	2 / 1	2 / 1	2 / 1	2 / 1	2 / 1	2 / 1	2 / 1
Fans	n°	2	2	2	2	2	2	2	3	3	3
Refrigerant		R454B	R454B	R454B	R454B	R454B	R454B	R454B	R454B	R454B	R454B
Refrigerant charge	kg	10,0	14,5	19,0	19,0	27,0	27,0	27,0	36,0	36,0	36,0
Global warming potential (GWP)		466	466	466	466	466	466	466	466	466	466
Equivalent CO ₂ charge	t	4,7	6,8	8,9	8,9	12,6	12,6	12,6	16,8	16,8	16,8
Water tank volume	l	140	140	300	300	300	300	300	500	500	500

HA/XL/HH-RV P2S		1792	2012	2304	2312	2654	2954	3214	3514	3954	4454
Heating capacity (EN14511) ⁽¹⁾	kW	181,0	200,0	229,0	227,0	267,0	300,0	320,0	365,0	407,0	456,0
Total input power (EN14511) ⁽¹⁾	kW	44,2	49,3	55,9	55,0	66,8	76,6	80,9	92,0	101,0	113,0
COP (EN14511) ⁽¹⁾	W/W	4,10	4,06	4,10	4,13	4,00	3,92	3,96	3,97	4,03	4,04
Energy Class ⁽²⁾		A++	A++	A++	A++	A+	A+	A++	A++	A++	A++
SCOP ⁽²⁾	kWh/kWh	4,09	4,09	3,86	4,09	3,82	3,79	3,89	3,88	3,85	3,84
η _{s,h} ⁽²⁾	%	161	161	151	161	150	149	153	152	151	151
Cooling capacity (EN14511) ⁽³⁾	kW	154,0	171,0	191	188,0	222,0	247,0	263,0	294,0	342,0	374,0
Total input power (EN14511) ⁽³⁾	kW	58,9	64,0	72,4	72,2	80,1	94,0	103,0	121,0	128,0	145,0
EER (EN14511) ⁽³⁾	W/W	2,61	2,67	2,65	2,60	2,77	2,63	2,55	2,43	2,67	2,58
TER (EN14511) ⁽⁴⁾	W/W	6,20	6,11	6,01	6,11	5,89	5,77	5,83	5,81	6,76	6,76
Sound power ⁽⁵⁾	dB (A)	81	82	80	83	83	84	84	84	86	86
Sound pressure ⁽⁶⁾	dB (A)	49	51	49	52	51	52	52	52	53	54
HE/XL/HH-RV P2S		1792	2012	2304	2312	2654	2954	3214	3514	3954	4454
Heating capacity (EN14511) ⁽¹⁾	kW	179,0	199,0	222,0	225,0	260,0	291,0	312,0	351,0	396,0	434,0
Total input power (EN14511) ⁽¹⁾	kW	42,1	47,0	52,7	52,7	61,6	71,7	75,9	87,0	95,3	107,0
COP (EN14511) ⁽¹⁾	W/W	4,25	4,23	4,21	4,27	4,22	4,06	4,11	4,03	4,16	4,06
Energy Class ⁽²⁾		A++	A++	A++	A++	A++	A++	A++	A++	A++	A++
SCOP ⁽²⁾	kWh/kWh	4,33	4,33	4,37	4,31	4,14	4,18	4,18	4,19	4,20	4,07
η _{s,h} ⁽²⁾	%	170	170	172	169	163	164	164	165	165	160
Cooling capacity (EN14511) ⁽³⁾	kW	151,0	166,0	187,0	181,0	219,0	244,0	259,0	286,0	337,0	367,0
Total input power (EN14511) ⁽³⁾	kW	58,8	64,7	71,2	73,6	77,2	91,4	101,0	120,0	125,0	143,0
EER (EN14511) ⁽³⁾	W/W	2,57	2,57	2,63	2,46	2,84	2,67	2,56	2,38	2,70	2,57
TER (EN14511) ⁽⁴⁾	W/W	6,20	6,11	6,01	6,11	5,89	5,77	5,83	5,81	6,76	6,89
Sound power ⁽⁵⁾	dB (A)	81	82	80	83	83	84	84	84	86	86
Sound pressure ⁽⁶⁾	dB (A)	49	51	49	52	51	52	52	52	53	54
Power supply	V/Ph/Hz	400/3/50	400/3/50	400/3/50	400/3/50	400/3/50	400/3/50	400/3/50	400/3/50	400/3/50	400/3/50
Compressors / Circuits	n° / n°	2 / 1	2 / 1	4 / 2	2 / 1	4 / 2	4 / 2	4 / 2	4 / 2	4 / 2	4 / 2
Fans	n°	3	3	4	3	6	6	6	6	8	8
Refrigerant		R454B	R454B	R454B	R454B	R454B	R454B	R454B	R454B	R454B	R454B
Refrigerant charge	kg	45,0	45,0	60,0	60,0	72,0	72,0	72,0	72,0	90,0	100,0
Global warming potential (GWP)		466	466	466	466	466	466	466	466	466	466
Equivalent CO ₂ charge	t	20,9	20,9	27,9	27,9	33,6	33,6	33,6	33,6	41,9	46,6
Water tank volume	l	500	500	500	500	500	500	500	500	500	500

Performances are referred to the following conditions:

(1) Heating: Ambient temperature 7°C DB, 6°C WB, water temperature 30/35°C.

(2) Average conditions, low temperature, variable - Reg EU 811/2013

(3) Cooling: ambient air temperature 35°C, evaporator water temperature in/out 12/7 °C (only rv versions).

(4) TER: Total Energy Ratio - cold circuit 12/7°C, hot circuit 30/35°C.

(5) Sound power level in accordance with ISO 3744.

(6) Sound pressure level at 10 mt from the unit in free field conditions in accordance with ISO 3744.

COMPONENTS

FRAME

All units are made from hot-galvanised sheet steel, painted with polyurethane powder enamel and stoved at 180°C to provide maximum protection against corrosion. The frame is self-supporting with removable panels. All screws and rivets used are made from stainless steel. The standard colour of the units is RAL9018.

REFRIGERANT CIRCUIT

The refrigerant circuit is assembled using internationally recognised brand name components with all brazing and welding being performed in accordance with ISO 97/23. The refrigerant utilised is R454B. The refrigerant circuit includes: sight glass, filter drier, electronic expansion valves, 4 way reversing valve, check valves, liquid receiver, liquid separator, schrader valves for maintenance and control, pressure safety device (for compliance with PED regulations).

COMPRESSORS

The compressors are scroll type, with crankcase resistance and thermal protection, installed in a separate compartment from the airflow in order to reduce noise. When the unit is on stand-by mode, the crankcase heater is always powered. Through the unit's front panel, it is possible to inspect and repair the compressors even when the unit is running.

The compressors used are tandem type. This solution allows a significantly higher efficiency with partial loads compared to the option with independent refrigerant circuits. The control system constantly monitors the discharge temperature of the single compressors.

SOURCE HEAT EXCHANGER

The source heat exchanger is made from 3/8" copper pipes and 0,1mm at least thick aluminium fins with the tubes being mechanically expanded into the aluminium fins in order to maximise heat transfer. Furthermore, the design guarantees a low air side pressure drop thus enabling the use of low rotation speed (and hence low noise) fans. All heat exchangers are supplied standard with fins hydrophilic coating "Blue Fins".

USER CIRCUIT HEAT EXCHANGERS

The user heat exchanger is a braze welded, plate type heat exchanger, manufactured from AISI 316 stainless steel. The use of this type of exchanger results in a massive reduction of the refrigerant charge of the unit compared to a traditional shell-in-tube type. A further advantage is a reduction in the overall dimensions of the unit. The exchangers are factory insulated with flexible close cell material and can be fitted with an antifreeze heater (accessory). Each exchanger is fitted with a temperature sensor on the discharge water side for antifreeze protection.

FANS

The fans are direct drive axial type with aerofoil blades, are statically and dynamically balanced and are supplied complete with a safety fan guard complying with the requirements of EN 60335. They are fixed to the unit frame via rubber anti-vibration mountings. The electric motors, in HA versions are 6 poles type and a phase-cut regulator controls their speed of rotation to increase energy efficiency and allow them to be used over a wider operating range. In the HE versions, the fans are electronic type, with permanent magnet motors with an integrated driver that modulates the speed of rotation. The motors are fitted with integrated thermal overload protection and have a moisture protection rating of IP 54.

MICROPROCESSORS

All units are supplied as standard with microprocessor controls. The microprocessor controls the following functions: control of the water temperature, antifreeze protection, compressor timing, compressor automatic starting sequence (For multiple compressors), alarm reset.

The control panel is supplied with display showing all operational icons. The microprocessor is set for automatic defrost (when operating in severe ambient conditions) and for summer/ winter change over. The control also manages the integration with other heating sources (electric heaters, boilers, solar panels etc) and both the heating circuit pump and the domestic hot water circuit pump. If required (available as an option), the microprocessor can be configured in order for it to connect to a site BMS system thus enabling remote control and management.

ELECTRIC ENCLOSURE

The enclosure is manufactured in order to comply with the requirements of the electromagnetic compatibility standards 2014/35/UE and 2014/30/UE. Access to the enclosure is achieved by removing the front panel of the unit. The following components are supplied as standard on all units: main switch, a sequence relay that disables the power supply in the event that the phase sequence is incorrect (scroll compressors can be damaged if they rotate in the wrong direction), thermal overloads (protection of pumps and fans), compressor fuses, control circuit automatic breakers, compressor contactors, fan contactors and pump contactors. The terminal board has volt free contacts for remote ON-OFF, Summer/ winter change over (heat pumps only) and general alarm.

CONTROL AND PROTECTION DEVICES

All units are standardly equipped with several control and safety devices: water return temperature sensor, installed on the water return pipe of the system, and anti-freeze probe, installed on the water supply pipe to the system high-pressure switch with automatic reset. There are also included a low-pressure automatic reset, pressure transducer (used to optimize the defrosting cycle and modulate the rotation speed of the fans according to external conditions), Freon side safety device, compressor thermal protection, fan thermal protection, flow switch, and external air compensation probe.

LEAK DETECTOR

When the unit is powered ON, the sensor is warmed up/initialised (duration approx. 1min.).

During this period, the LEDs inside the sensor blink, the refrigerant leakage alarm is notified and the 24Vac auxiliary circuit is switched off. After this period, if in the absence of any further feedback from the sensor, the PLC control is powered up and the unit is ready to operate. If refrigerant leaks occur, the sensor is activated and the power supply to the control PLC is immediately switched off until the sensor indicates the refrigerant is still present.

VERSION

HA/XL HE/XL Super low noise version

All XL super silenced units are supplied equipped with a special vibration-damping system consisting of a floating basement placed upon the unit's frame, through the interposition of high-damping steel springs.

The compressors are housed on this floating base and are in turn fixed by means of rubber anti-vibration supports.

The enclosure is manufactured from galvanized steel sandwich panels that have a micro-perforated inner skin and a core of 30 mm thick, high density (25 kg/m³) soundproofing mat. The entire arrangement provides a double damping system and acoustic attenuation. The compressor refrigerant pipes are connected to the refrigerant circuit through "anaconda" flexible connections. Flexible connections are also used on the water pipework within the unit. The combination of these systems results in an overall noise reduction in the region of 6-8 dB(A) compared to units in standard configuration.

HH Version

HH heating only versions are available in the P2U and P2S configuration only.

RV Version

This version uses 2 hydraulic connections and is able to produce hot water in winter and cold water in summer. The unit is combined with a 2-pipe system.

HA Version

High efficiency version, according to current standard. Unit equipped with AC fans.

HE Version

High efficiency version, according to current standard. Unit equipped with EC fans.

LS Version

This version includes the complete acoustic insulation of the unit with compressor jackets and insulating material made with high density media and the interposition of heavy bitumen layer.

P2U Version

This is a two pipe version that can produce hot water for heating (HH heating only) and hot or cold water in the RV version. The RV is used with two pipe water based change-over systems. It is not able to produce domestic hot water.

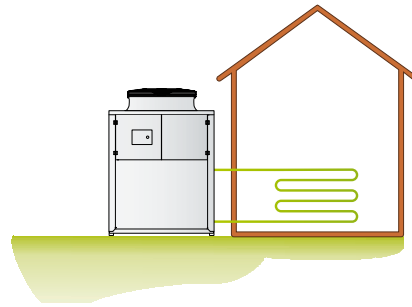

P2S Version

This is a two pipe version that can, in addition to producing hot water for heating and cold water for cooling, also generate domestic hot water. The controller has dual heating set points (heating and DHW) and can also control a three port diverting valve that directs the DHW to the cylinder. DHW production has priority irrespective of the mode of operation of the unit. The unit is normally used with two pipe water based change-over systems.

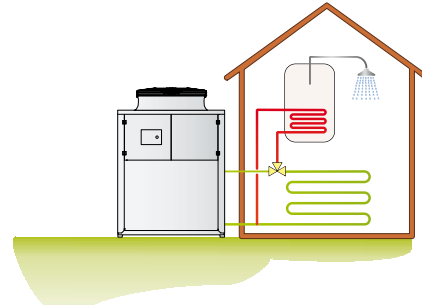

OPERATION LIMITS

(HA/HE versions)

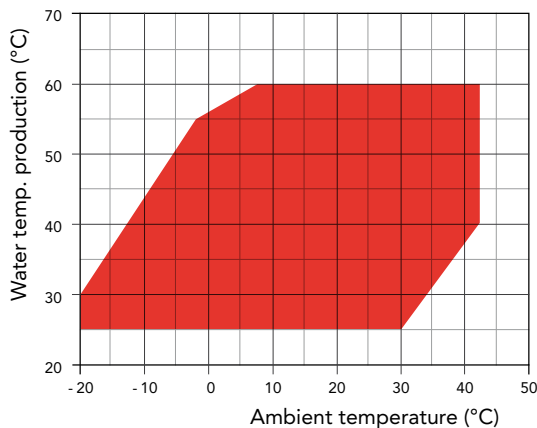

■ Heating mode

(RV versions Only)

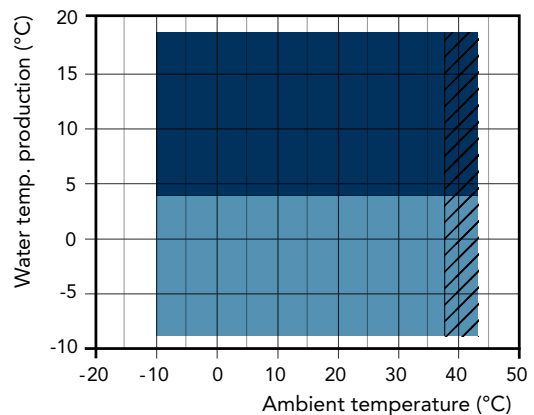

■ Cooling mode

■ Glycol set-up

Possible noise increase for XL versions

ACCESSORIES

LHE HA-HE /HH-RV		452	512	682	752	912	1102	1152	1352	1502	1612
Flow switch		●	●	●	●	●	●	●	●	●	●
Floating frame technology - LS version		-	-	-	-	-	-	-	-	-	-
Floating frame technology - XL version		●	●	●	●	●	●	●	●	●	●
Hydraulic kit with storage tank and one low-pressure pump	A1LLU	○	○	○	○	○	○	○	○	○	○
Hydraulic kit with one low-pressure pump	A1LPU	○	○	○	○	○	○	○	○	○	○
Hydraulic kit with one pump without tank - user circuit	A1NTU	○	○	○	○	○	○	○	○	○	○
User circuit hydraulic kit, one inverter pump, no tank	A1VSU	○	○	○	○	○	○	○	○	○	○
User circuit hydraulic kit + inverter centrifugal pump	A1VVU	○	○	○	○	○	○	○	○	○	○
Integrated hydraulic kit 1 pump + Water tank	A1ZZU	○	○	○	○	○	○	○	○	○	○
Hydraulic kit with two pumps without tank - user circuit	A2NTU	○	○	○	○	○	○	○	○	○	○
Integrated hydraulic kit 2 pumps + Water tank	A2ZZU	○	○	○	○	○	○	○	○	○	○
Condensate discharge drip tray with antifreeze heater	BRCA	○	○	○	○	○	○	○	○	○	○
Low Temperature Operating	BT	○	○	○	○	○	○	○	○	○	○
4-connection tank and low-pressure pump	BUF4A	○	○	○	○	○	○	○	○	○	○
Fans regulation by phase cut (HA version)	DCCF	●	●	●	●	●	●	●	●	●	●
Refrigerant leakage detector	DFR	●	●	●	●	●	●	●	●	●	●
Electronic soft starter	DSSE	○	○	○	○	○	○	○	○	○	○
Double safety valve	DSV	○	○	○	○	○	○	○	○	○	○
Coil protection grid	GBPE	○	○	○	○	○	○	○	○	○	○
WIFI Application	HIPRO.web	○	○	○	○	○	○	○	○	○	○
Display	HMI.PRO	●	●	●	●	●	●	●	●	●	●
Serial interface card RS485	INSE	●	●	●	●	●	●	●	●	●	●
Rubber vibration dampers	KAVG	○	○	○	○	○	○	○	○	○	○
Spring vibration dampers	KAVM	○	○	○	○	○	○	○	○	○	○
COP internal optimizer kit	KCOP	○	○	○	○	○	○	○	○	○	○
Lifting rings kit	KGS	●	●	●	●	●	●	●	●	●	●
Safety valve ducting aid kit	KCSV	●	●	●	●	●	●	●	●	●	●
Double safety valve ducting aid kit	KCDV	○	○	○	○	○	○	○	○	○	○
Tank antifreeze kit	KPSU	○	○	○	○	○	○	○	○	○	○
User antifreeze kit	KPU	○	○	○	○	○	○	○	○	○	○
Victaulic kit	KVICT	-	-	-	-	-	-	-	-	-	-
Pressure gauges	MAML	○	○	○	○	○	○	○	○	○	○
Remote control panel	PCRL	○	○	○	○	○	○	○	○	○	○
Shut-off valve on compressor discharging side	RDCO	○	○	○	○	○	○	○	○	○	○
Cascade control system via RS485	SGRS	○	○	○	○	○	○	○	○	○	○
DHW probe kit	SOND1	●	●	●	●	●	●	●	●	●	●
E.C. fans - HA versions	VECE	-	-	-	-	-	-	-	-	-	-
E.C. fans - HE versions	VECE	●	●	●	●	●	●	●	●	●	●
Electronic expansion valve	VTEE	●	●	●	●	●	●	●	●	●	●

● Standard ○ Optional – Not available

LHE HA-HE /HH-RV		1792	2012	2304	2312	2654	2954	3214	3514	3954	4454
Flow switch		●	●	●	●	●	●	●	●	●	●
Floating frame technology - LS version		-	-	-	-	-	-	-	-	-	-
Floating frame technology - XL version		●	●	●	●	●	●	●	●	●	●
Hydraulic kit with storage tank and one low-pressure pump	A1LLU	○	○	○	○	○	○	○	○	○	○
Hydraulic kit with one low-pressure pump	A1LPU	○	○	○	○	○	○	○	○	○	○
Hydraulic kit with one pump without tank - user circuit	A1NTU	○	○	○	○	○	○	○	○	○	○
User circuit hydraulic kit, one inverter pump, no tank	A1VSU	○	○	○	○	○	○	○	○	○	○
User circuit hydraulic kit + inverter centrifugal pump	A1VVU	○	○	○	○	○	○	○	○	○	○
Integrated hydraulic kit 1 pump + Water tank	A1ZZU	○	○	○	○	○	○	○	○	○	○
Hydraulic kit with two pumps without tank - user circuit	A2NTU	○	○	○	○	○	○	○	○	○	○
Integrated hydraulic kit 2 pumps + Water tank	A2ZZU	○	○	○	○	○	○	○	○	○	○
Condensate discharge drip tray with antifreeze heater	BRCA	○	○	○	○	○	○	○	○	○	○
Low Temperature Operating	BT	○	○	○	○	○	○	○	○	○	○
4-connection tank and low-pressure pump	BUF4A	○	○	○	○	○	○	○	○	○	○
Fans regulation by phase cut (HA version)	DCCF	●	●	●	●	●	●	●	●	●	●
Refrigerant leakage detector	DFR	●	●	●	●	●	●	●	●	●	●
Electronic soft starter	DSSE	○	○	○	○	○	○	○	○	○	○
Double safety valve	DSV	○	○	○	○	○	○	○	○	○	○
Coil protection grid	GBPE	○	○	○	○	○	○	○	○	○	○
WIFI Application	HIPRO.web	○	○	○	○	○	○	○	○	○	○
Display	HMI.PRO	●	●	●	●	●	●	●	●	●	●
Serial interface card RS485	INSE	●	●	●	●	●	●	●	●	●	●
Rubber vibration dampers	KAVG	○	○	○	○	○	○	○	○	○	○
Spring vibration dampers	KAVM	○	○	○	○	○	○	○	○	○	○
COP internal optimizer kit	KCOP	○	○	○	○	○	○	○	○	○	○
Lifting rings kit	KGS	●	●	●	●	●	●	●	●	●	●
Safety valve ducting aid kit	KCSV	●	●	●	●	●	●	●	●	●	●
Double safety valve ducting aid kit	KCDV	○	○	○	○	○	○	○	○	○	○
Tank antifreeze kit	KPSU	○	○	○	○	○	○	○	○	○	○
User antifreeze kit	KPU	○	○	○	○	○	○	○	○	○	○
Victaulic kit	KVICT	●	●	●	●	●	●	●	●	●	●
Pressure gauges	MAML	○	○	○	○	○	○	○	○	○	○
Remote control panel	PCRL	○	○	○	○	○	○	○	○	○	○
Shut-off valve on compressor discharging side	RDCO	○	○	○	○	○	○	○	○	○	○
Cascade control system via RS485	SGRS	○	○	○	○	○	○	○	○	○	○
DHW probe kit	SOND1	●	●	●	●	●	●	●	●	●	●
E.C. fans - HA versions	VECE	-	-	-	-	-	-	-	-	-	-
E.C. fans - HE versions	VECE	●	●	●	●	●	●	●	●	●	●
Electronic expansion valve	VTEE	●	●	●	●	●	●	●	●	●	●

● Standard ○ Optional - Not available

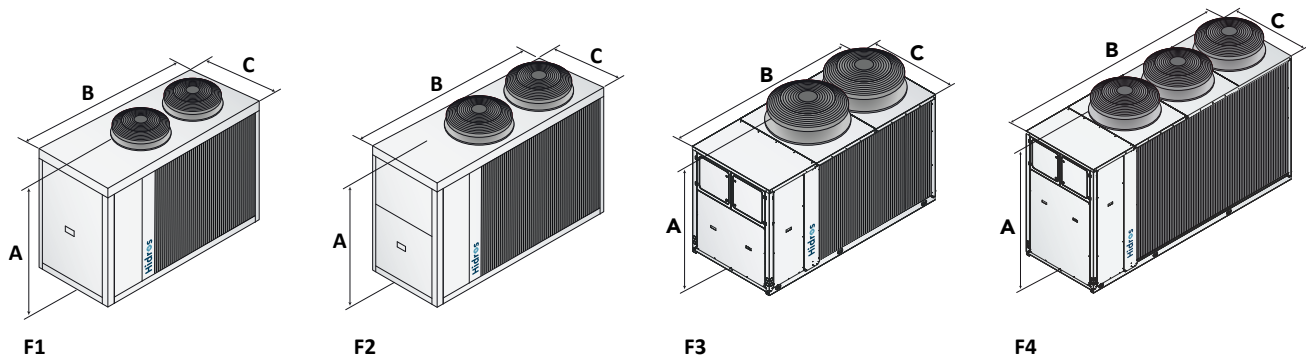

	452	512	682	752	912	1102	1152	1352	1502	1612
A (mm)	1673	1673	1839	1839	1918	1918	1918	1918	1918	1918
B (mm)	2400	2400	3000	3000	3000	3000	3000	4295	4295	4295
C (mm)	1265	1265	1265	1265	1265	1265	1265	1265	1265	1265
Kg	650	658	884	890	1100	1108	1110	1688	1714	1722
FRAME	F1	F1	F2	F2	F3	F3	F3	F4	F4	F4

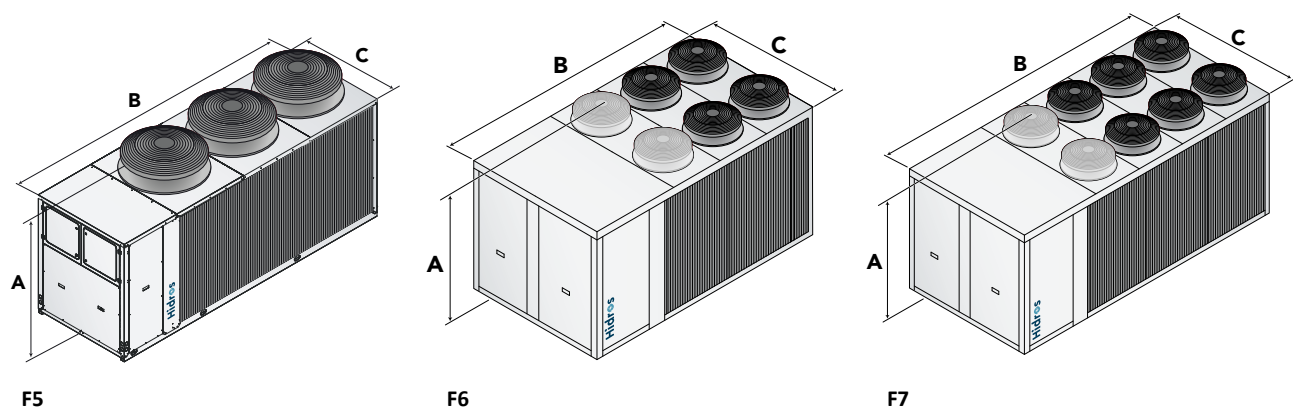

	1792	2012	2304	2312	2654	2954	3214	3514	3954	4454
A (mm)	1918	2287	2378	2287	2378	2378	2378	2378	2378	2378
B (mm)	4295	4296	4515	4296	4515	4515	4515	4515	5557	5557
C (mm)	1265	1265	2310	1265	2310	2310	2310	2310	2310	2310
Kg	1776	1762	1778	3262	3348	3438	3438	3508	3658	3686
FRAME	F4	F5	F6	F5	F6	F6	F6	F6	F7	F7